

21 20 19 18 17 16 15 14 13 12 11 10 9 8 7 6 5 4 3 2 1

A B C D E F G H I J K L M N O P Q R S T U V

<p>ESTI DOCUMENTO CONTIENE INFORMACION DE PROPIEDAD DE          CICC S.A. Y SU USO ESTRICTAMENTE LIMITADO. Queda prohibida la          reproduccion o cualquier otro uso no autorizado sin el consentimiento escrito de CICC S.A.</p>		<p>00          A          DC          GR          05</p>	<p>PARA LICITACION</p>																																																																					
<p>PROYECTO: OBRAS DE RECONSTRUCCION DEL PUEBLO NEGRO DE RIO NEGRO</p>																																																																								
<p>PROPIETARIO: PODER JUDICIAL DE RIO NEGRO</p>																																																																								
<p>PROYECTISTA: CICC S.A. CIPOLLETTI</p>																																																																								
<p>INDICACIONES:</p> <table border="1"> <thead> <tr> <th>REV.</th> <th>FECHA</th> <th>DESCRIPCION</th> </tr> </thead> <tbody> <tr><td>0</td><td>A</td><td>A</td></tr> <tr><td>1</td><td>A</td><td>A</td></tr> <tr><td>2</td><td>A</td><td>A</td></tr> <tr><td>3</td><td>A</td><td>A</td></tr> <tr><td>4</td><td>A</td><td>A</td></tr> <tr><td>5</td><td>A</td><td>A</td></tr> <tr><td>6</td><td>A</td><td>A</td></tr> <tr><td>7</td><td>A</td><td>A</td></tr> <tr><td>8</td><td>A</td><td>A</td></tr> <tr><td>9</td><td>A</td><td>A</td></tr> <tr><td>10</td><td>A</td><td>A</td></tr> <tr><td>11</td><td>A</td><td>A</td></tr> <tr><td>12</td><td>A</td><td>A</td></tr> <tr><td>13</td><td>A</td><td>A</td></tr> <tr><td>14</td><td>A</td><td>A</td></tr> <tr><td>15</td><td>A</td><td>A</td></tr> <tr><td>16</td><td>A</td><td>A</td></tr> <tr><td>17</td><td>A</td><td>A</td></tr> <tr><td>18</td><td>A</td><td>A</td></tr> <tr><td>19</td><td>A</td><td>A</td></tr> <tr><td>20</td><td>A</td><td>A</td></tr> <tr><td>21</td><td>A</td><td>A</td></tr> </tbody> </table>				REV.	FECHA	DESCRIPCION	0	A	A	1	A	A	2	A	A	3	A	A	4	A	A	5	A	A	6	A	A	7	A	A	8	A	A	9	A	A	10	A	A	11	A	A	12	A	A	13	A	A	14	A	A	15	A	A	16	A	A	17	A	A	18	A	A	19	A	A	20	A	A	21	A	A
REV.	FECHA	DESCRIPCION																																																																						
0	A	A																																																																						
1	A	A																																																																						
2	A	A																																																																						
3	A	A																																																																						
4	A	A																																																																						
5	A	A																																																																						
6	A	A																																																																						
7	A	A																																																																						
8	A	A																																																																						
9	A	A																																																																						
10	A	A																																																																						
11	A	A																																																																						
12	A	A																																																																						
13	A	A																																																																						
14	A	A																																																																						
15	A	A																																																																						
16	A	A																																																																						
17	A	A																																																																						
18	A	A																																																																						
19	A	A																																																																						
20	A	A																																																																						
21	A	A																																																																						
<p>DESCRIPCION: DETALLE CONSTRUCTIVO TIPO E</p>																																																																								
<p>EMBITO: A3 CONTROL: JU</p>																																																																								
<p>FECHA: 26/05/15 ESCALA: 1:10</p>																																																																								
<p>PROYECTISTA: CICC S.A. CIPOLLETTI</p>																																																																								

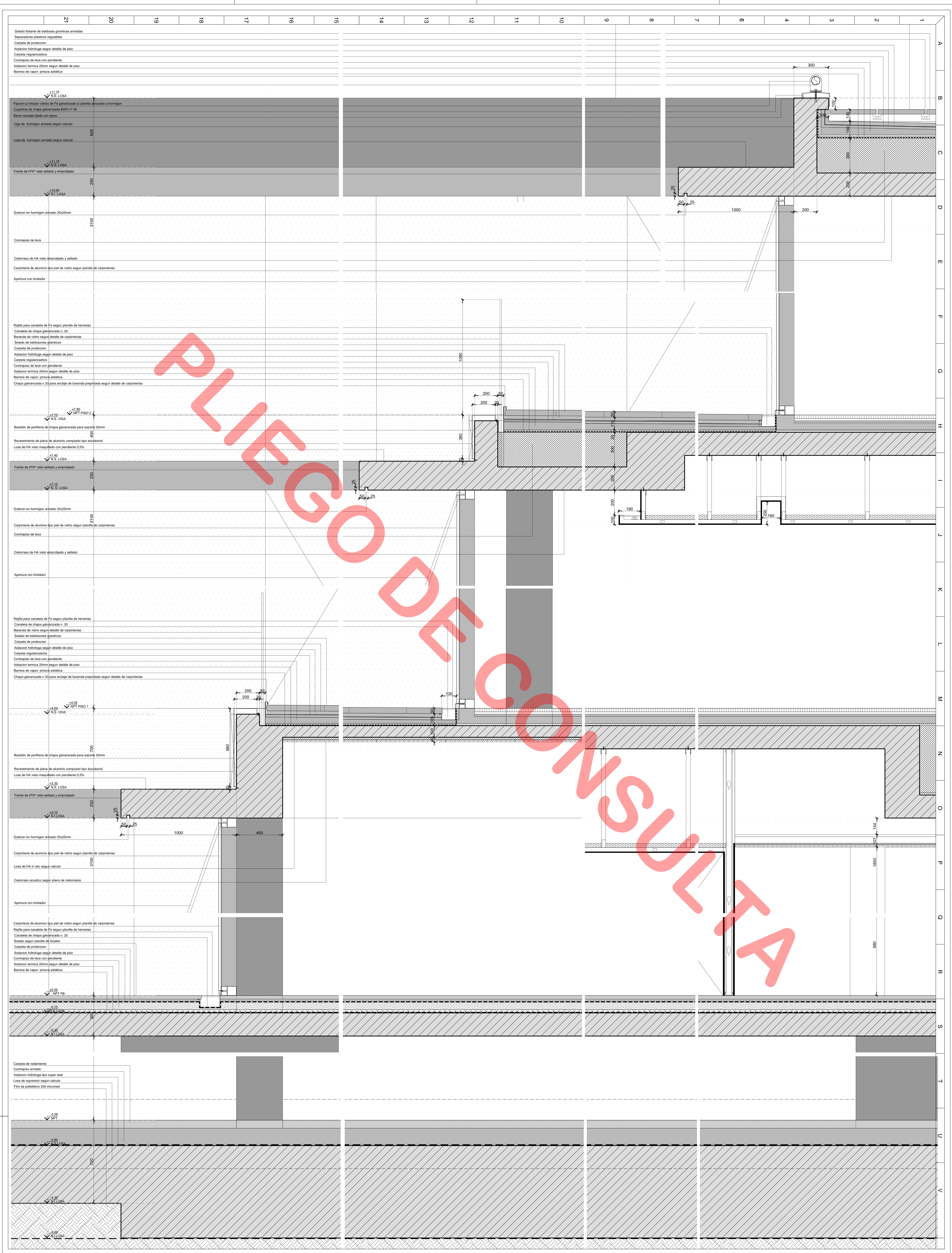



00	01	02	03	04	05	06	07	08
00	A	DC	GR	GR	GR	GR	GR	08

ESTI DOCUMENTO CONTIENE INFORMACION DE PROYECTO DE CONSULTA. CUALQUIER USO NO AUTORIZADO DE ESTE DOCUMENTO CONSTITUYE UN INFRACCIÓN DE LEY. SE DESLIEGA DE TODA RESPONSABILIDAD POR LOS DAÑOS QUE PUEDAN SUCCEDER COMO CONSECUENCIA DEL USO NO AUTORIZADO DE ESTE DOCUMENTO.

PROYECTO: C/ OLYMPIA MICHÓN

PROYECTISTA: C/ COLLETTI

PROPIETARIO: PODER JUDICIAL DE RIO NEGRO

DESCRIPCIÓN: DETALLE CONSTRUCTIVO TIPO H

FECHA: 26/09/15

ESCALA: 1:10

CONTROLADO: JU

PROYECTISTA: PARRA LUTERANO

MODIFICACIONES	REV.	FECHA	DESCRIPCION
	0	A	A
	1	A	A
	2	A	A
	3	A	A
	4	A	A
	5	A	A
	6	A	A
	7	A	A
	8	A	A
	9	A	A
	10	A	A
	11	A	A
	12	A	A
	13	A	A
	14	A	A
	15	A	A
	16	A	A
	17	A	A
	18	A	A
	19	A	A
	20	A	A
	21	A	A

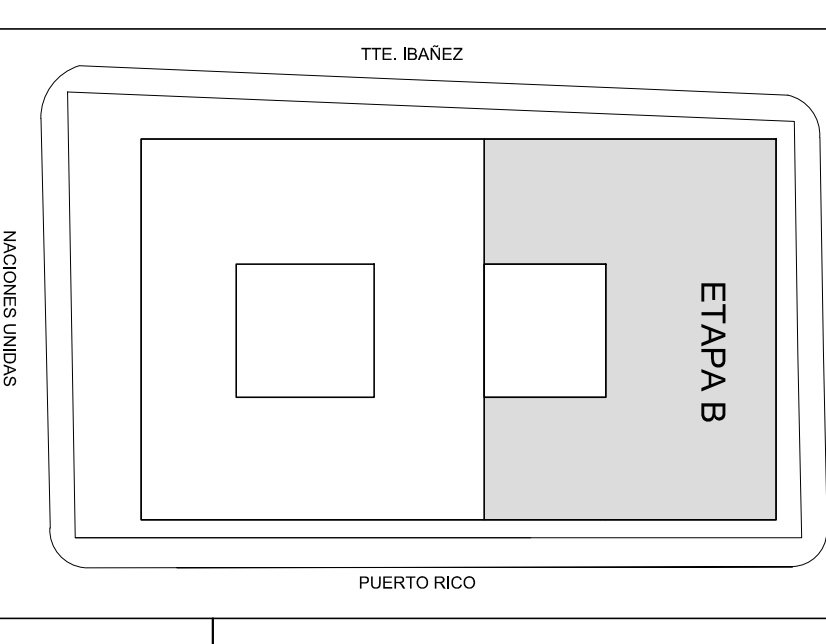
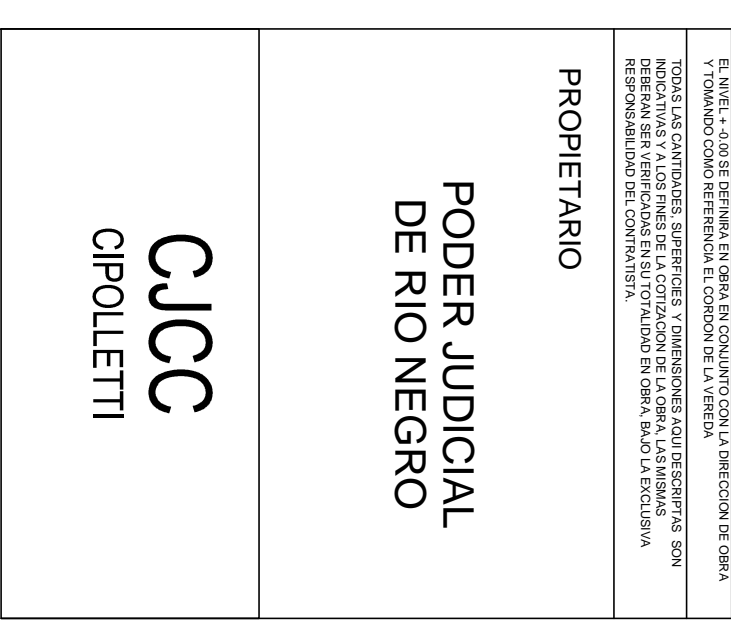

PROYECTO: C/ OLYMPIA MICHÓN

PROYECTISTA: C/ COLLETTI

PROPIETARIO: PODER JUDICIAL DE RIO NEGRO

DESCRIPCIÓN: DETALLE CONSTRUCTIVO TIPO H

FECHA: 26/09/15

ESCALA: 1:10

CONTROLADO: JU

PROYECTISTA: PARRA LUTERANO

ESTI DOCUMENTO CONTIENE INFORMACION DE PROYECTO DE CONSULTA. CUALQUIER USO NO AUTORIZADO DE ESTE DOCUMENTO CONSTITUYE UN INFRACCIÓN DE LEY. SE DESLIEGA DE TODA RESPONSABILIDAD POR LOS DAÑOS QUE PUEDAN SUCCEDER COMO CONSECUENCIA DEL USO NO AUTORIZADO DE ESTE DOCUMENTO.

PROYECTO: C/ OLYMPIA MICHÓN

PROYECTISTA: C/ COLLETTI

PROPIETARIO: PODER JUDICIAL DE RIO NEGRO

DESCRIPCIÓN: DETALLE CONSTRUCTIVO TIPO H

FECHA: 26/09/15

ESCALA: 1:10

CONTROLADO: JU

PROYECTISTA: PARRA LUTERANO



VISTA 1.50

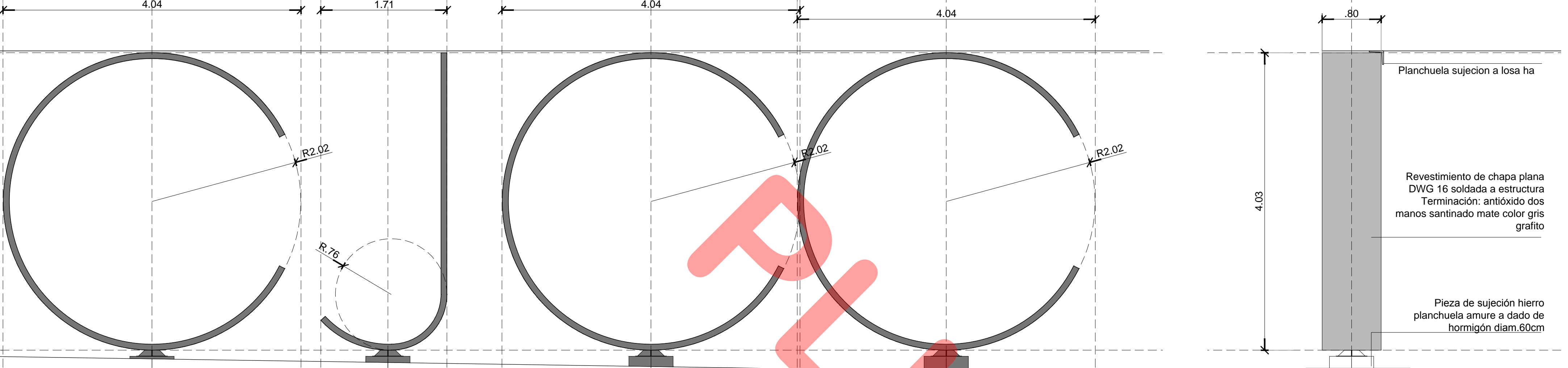

PLANTA 1.50

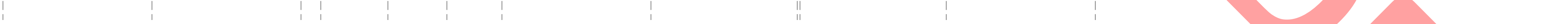

PLANTA 1.50  
PROVISORIO EN ETAPA A  
CONTRAFRENTE

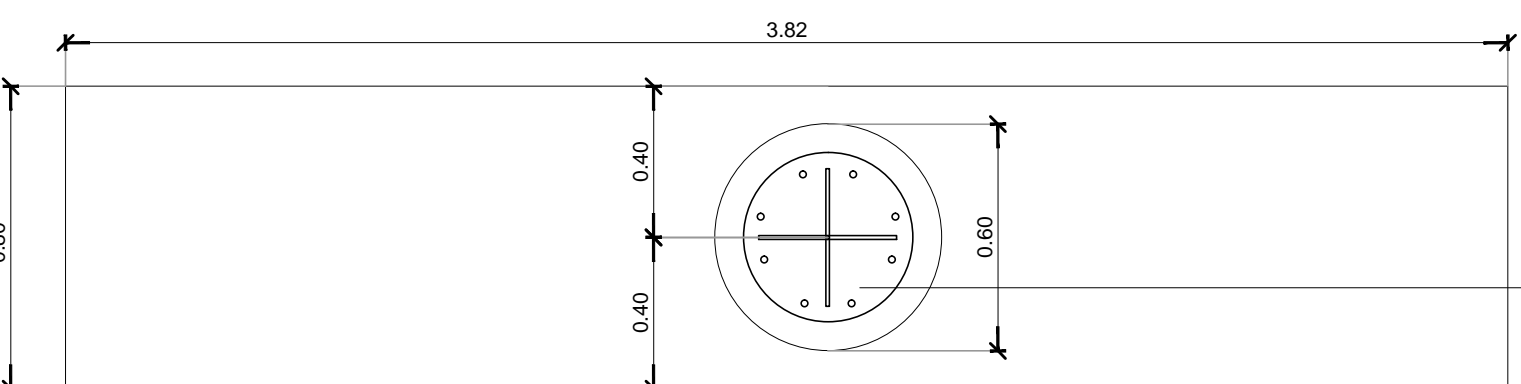

PLANTA DE APOYO INFERIOR  
ESC.1.20

VISTA ESTRUCTURA  
ESC.1.20

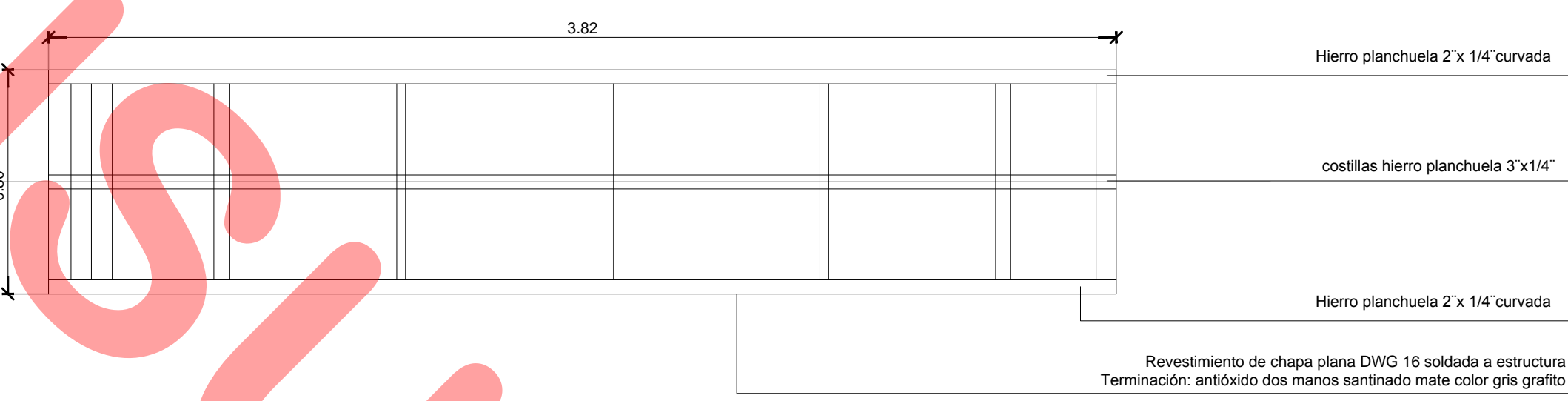
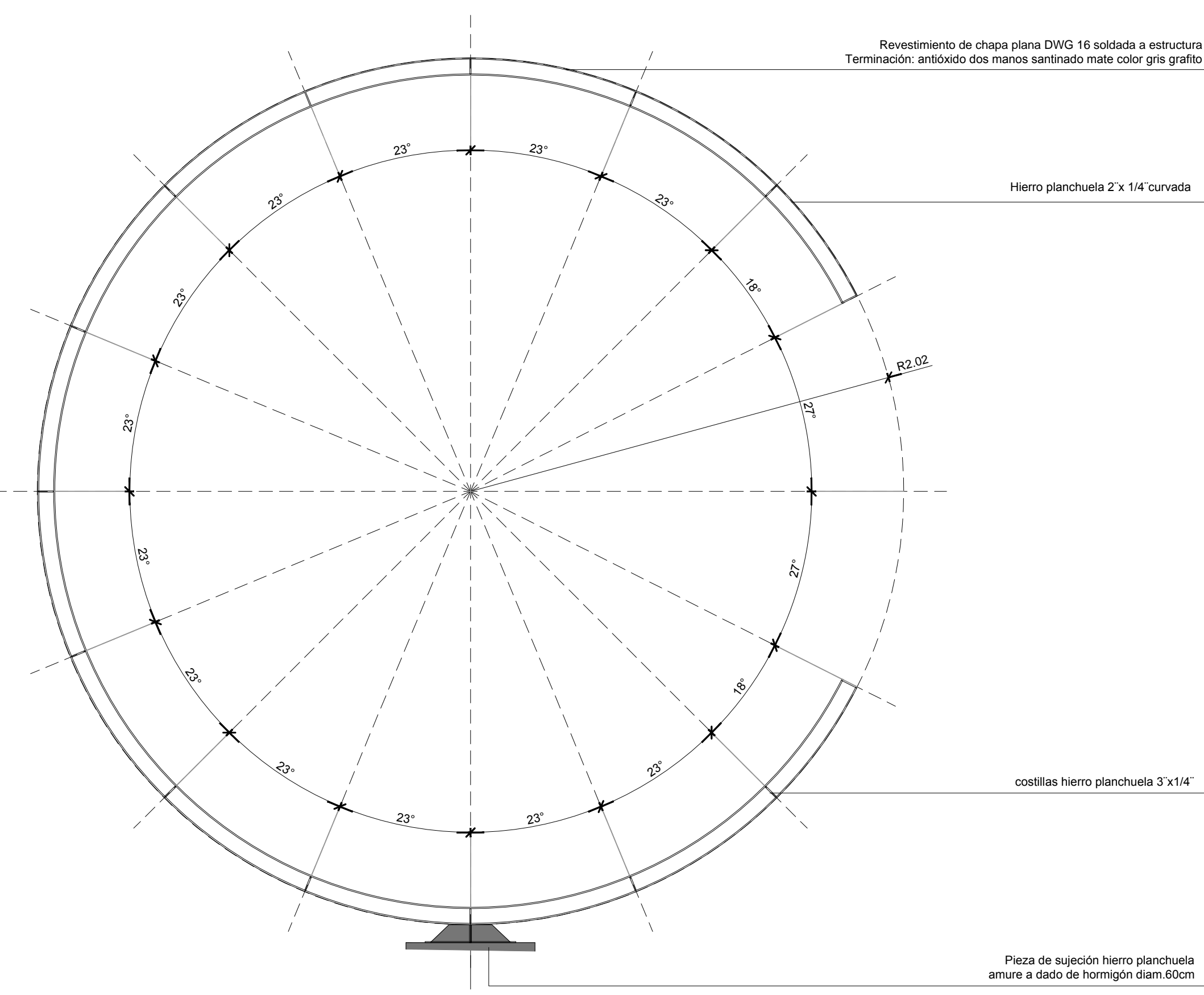

VISTA ESTRUCTURA  
ESC.1.20

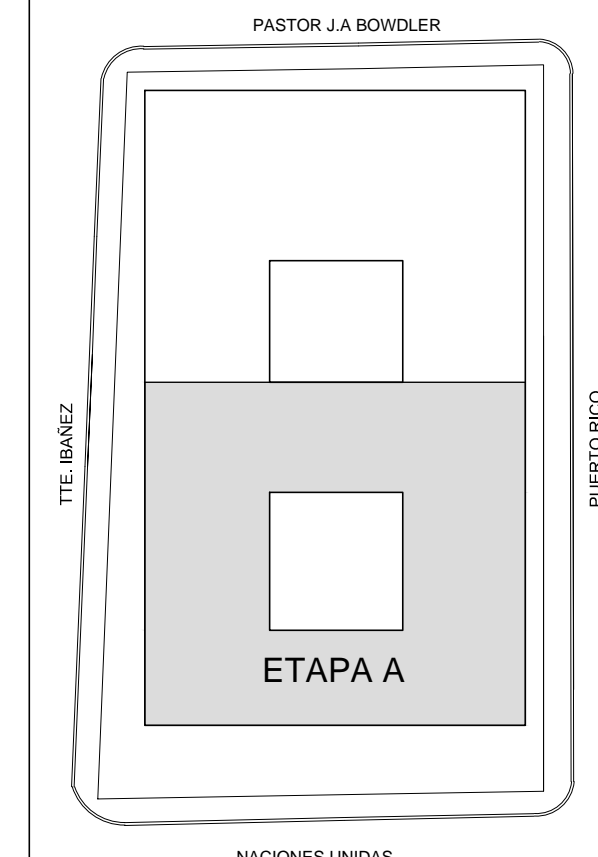

PROPIETARIO  
**PODER JUDICIAL  
 DE RIO NEGRO**  
  
**CJCC  
 CIPOLLETTI**

REV.	FECHA	DESCRIPCION
D	A	A
A	A	A
A	A	A
A	A	A
A	A	A
A	A	A
A	A	A
A	A	A
A	A	A
A	A	A

PROYECTO  
 CHERRENCO-COHAS-TYSBEROWICZ-VIGHONI  
 arquitectos  
 11 de septiembre 2008 of. C14384/F - Ciudad de Buenos Aires, Argentina  
 TEL: 011 4790 2665

DIBUJO: AS CONTROL: JU  
 FECHA: 24.09.15 ESCALA: 1:50/1:20

DESCRIPCION  
**DETALLE CONSTRUCTIVO  
 LETRAS CORPOREAS  
 ETAPA A**

ESTE DOCUMENTO CONTIENE INFORMACION DE PROPIEDAD DE  
 CJCC. SU REPRODUCCION TOTAL O PARCIAL, SIN NUESTRA  
 APROBACION ESCRITA ESTA PROHIBIDA.

00	A	PARA LICITACION
CJCC	DC	LC



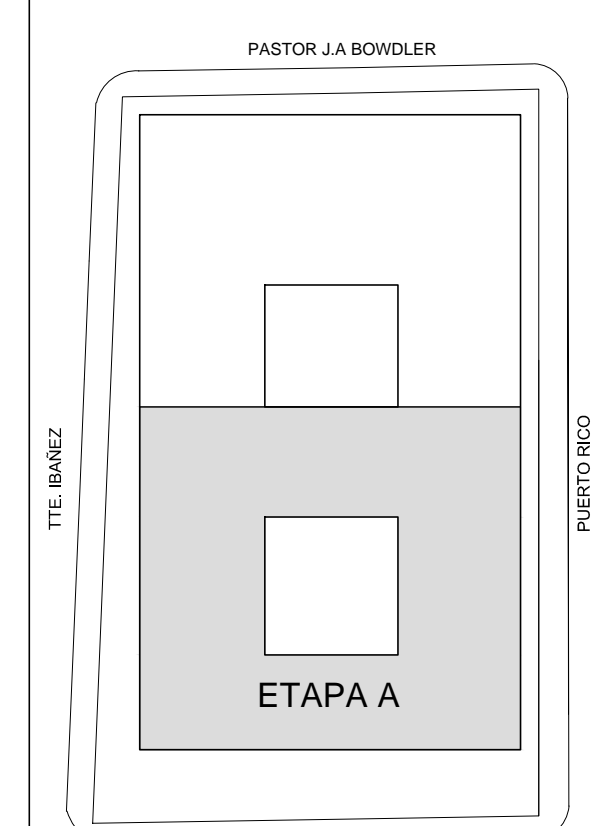
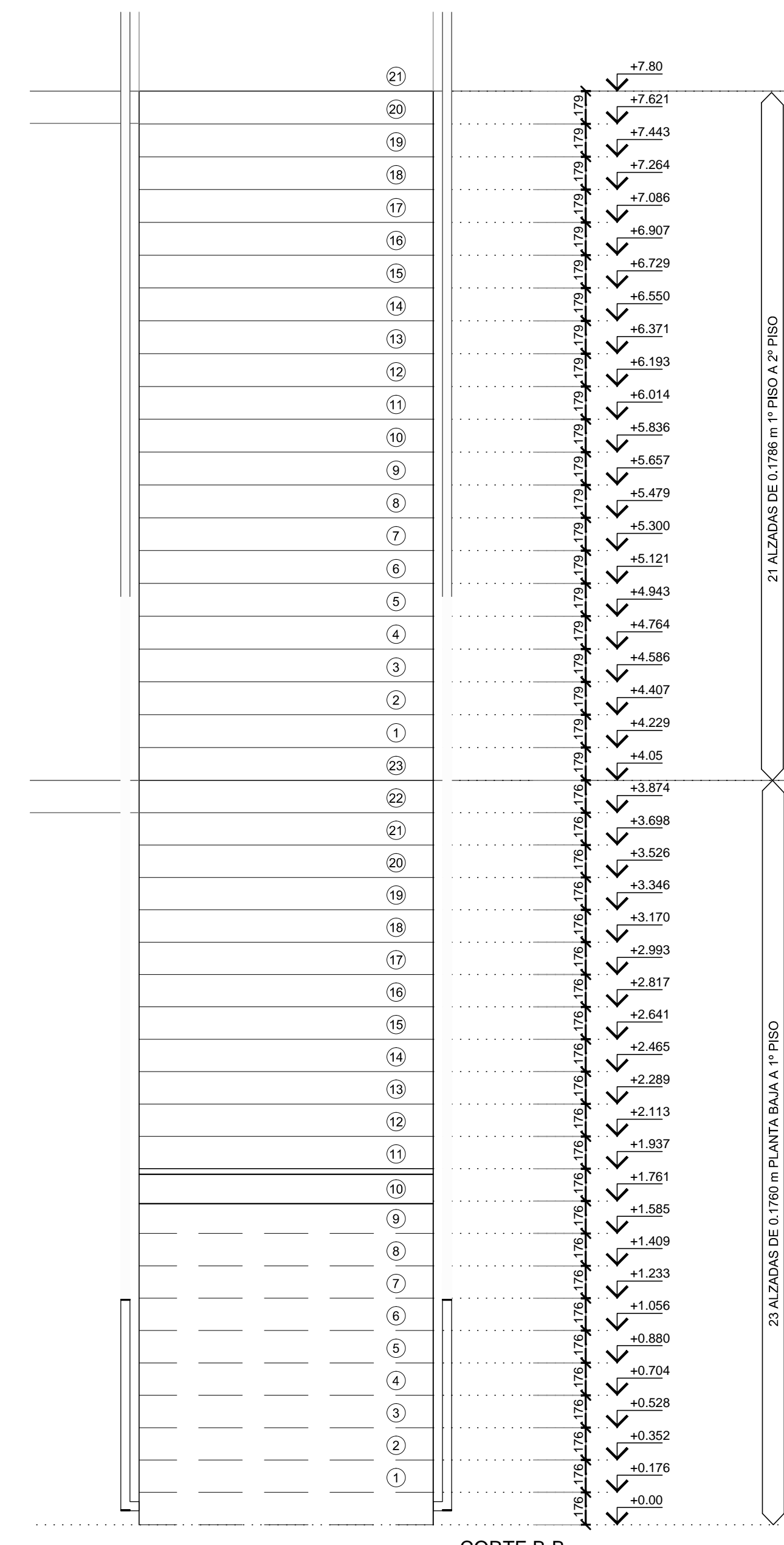
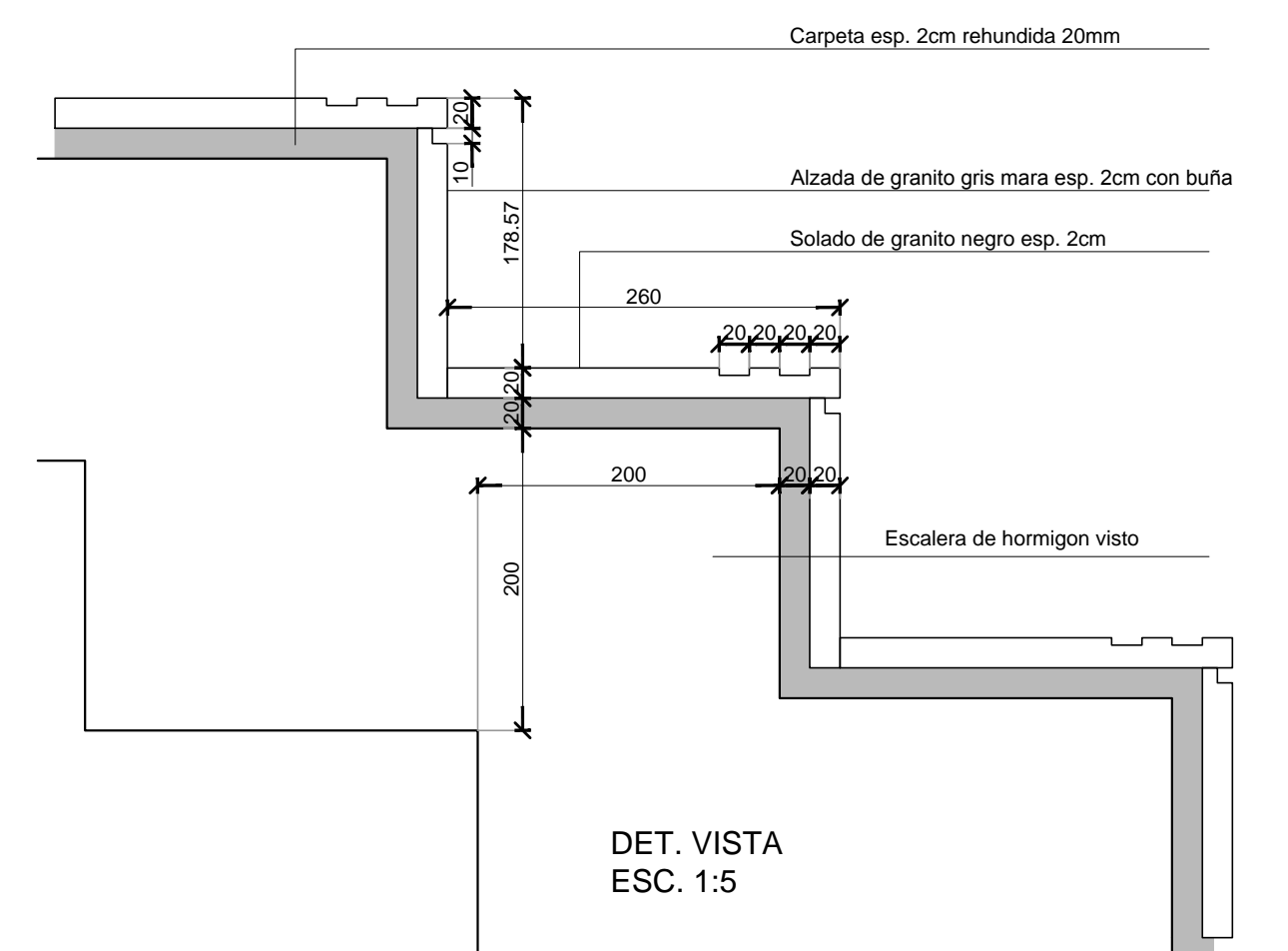
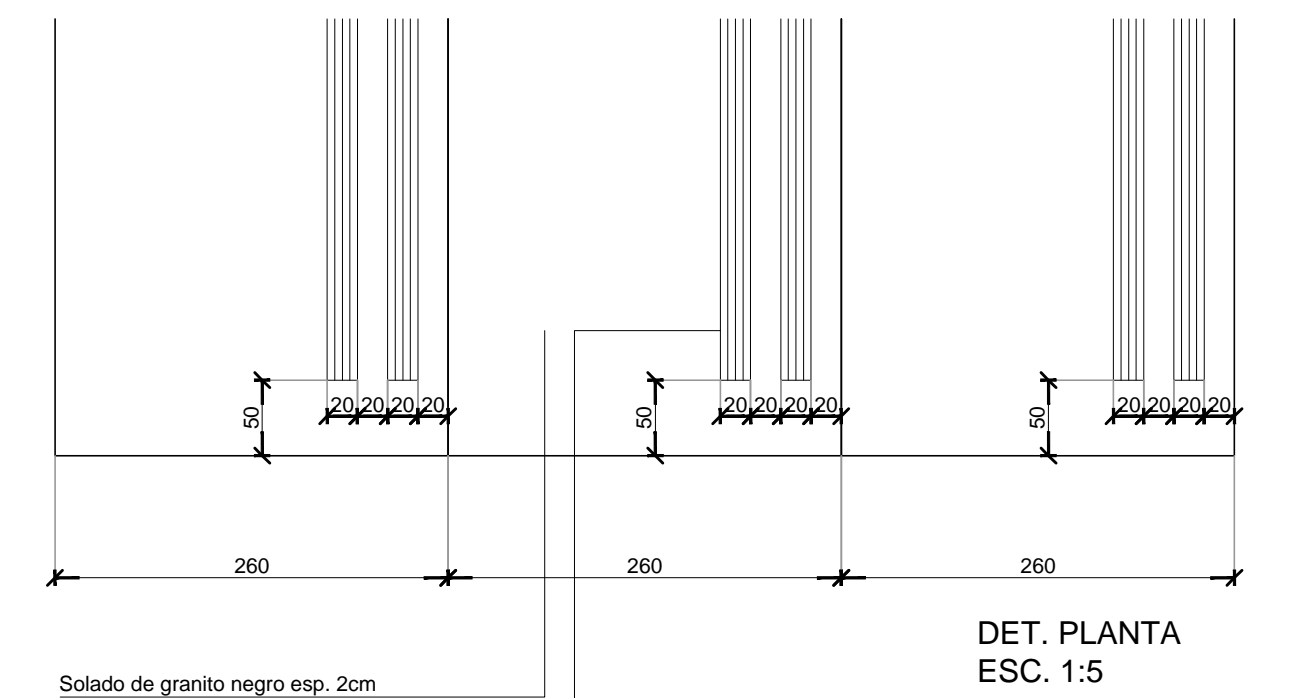
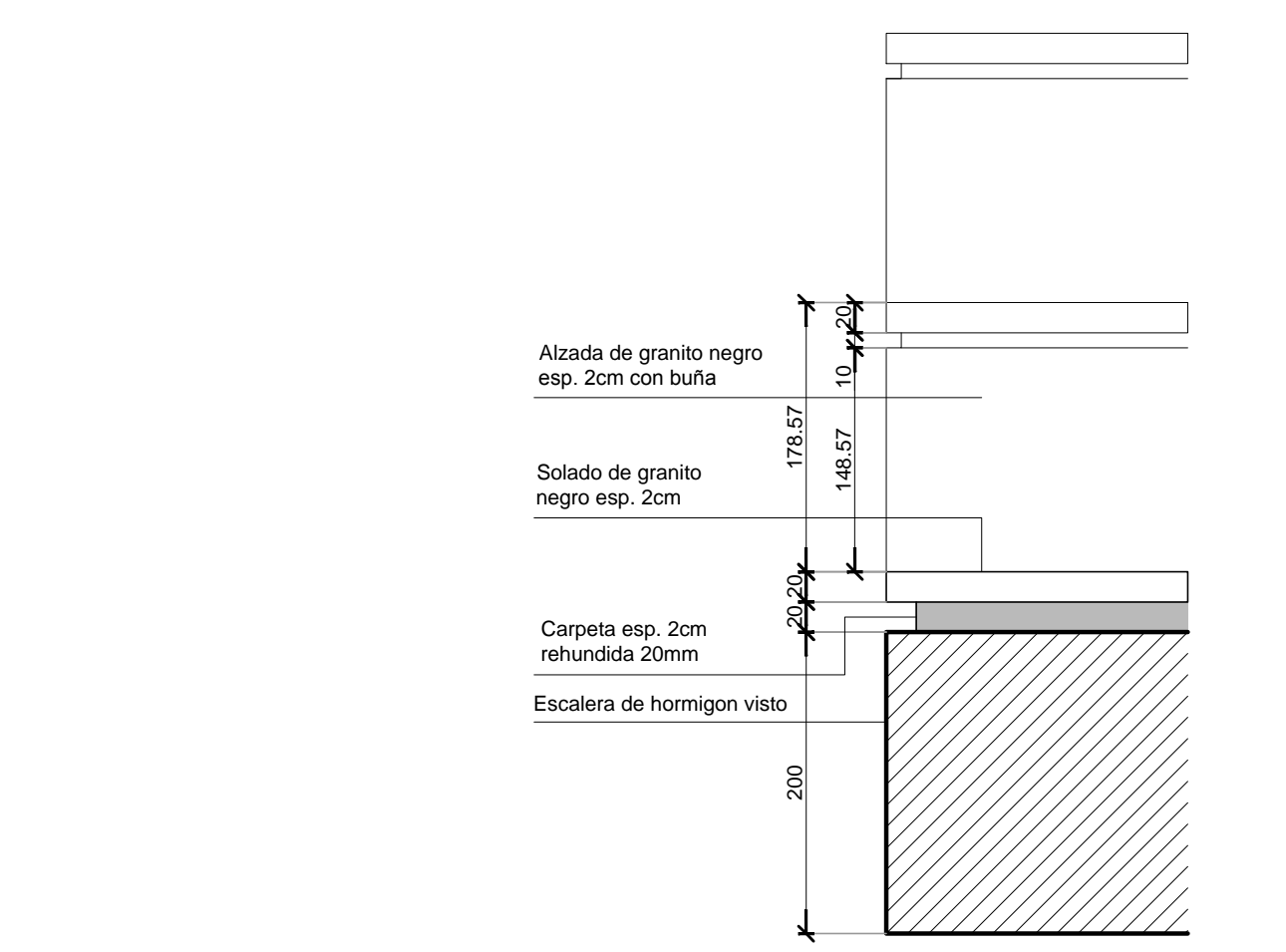
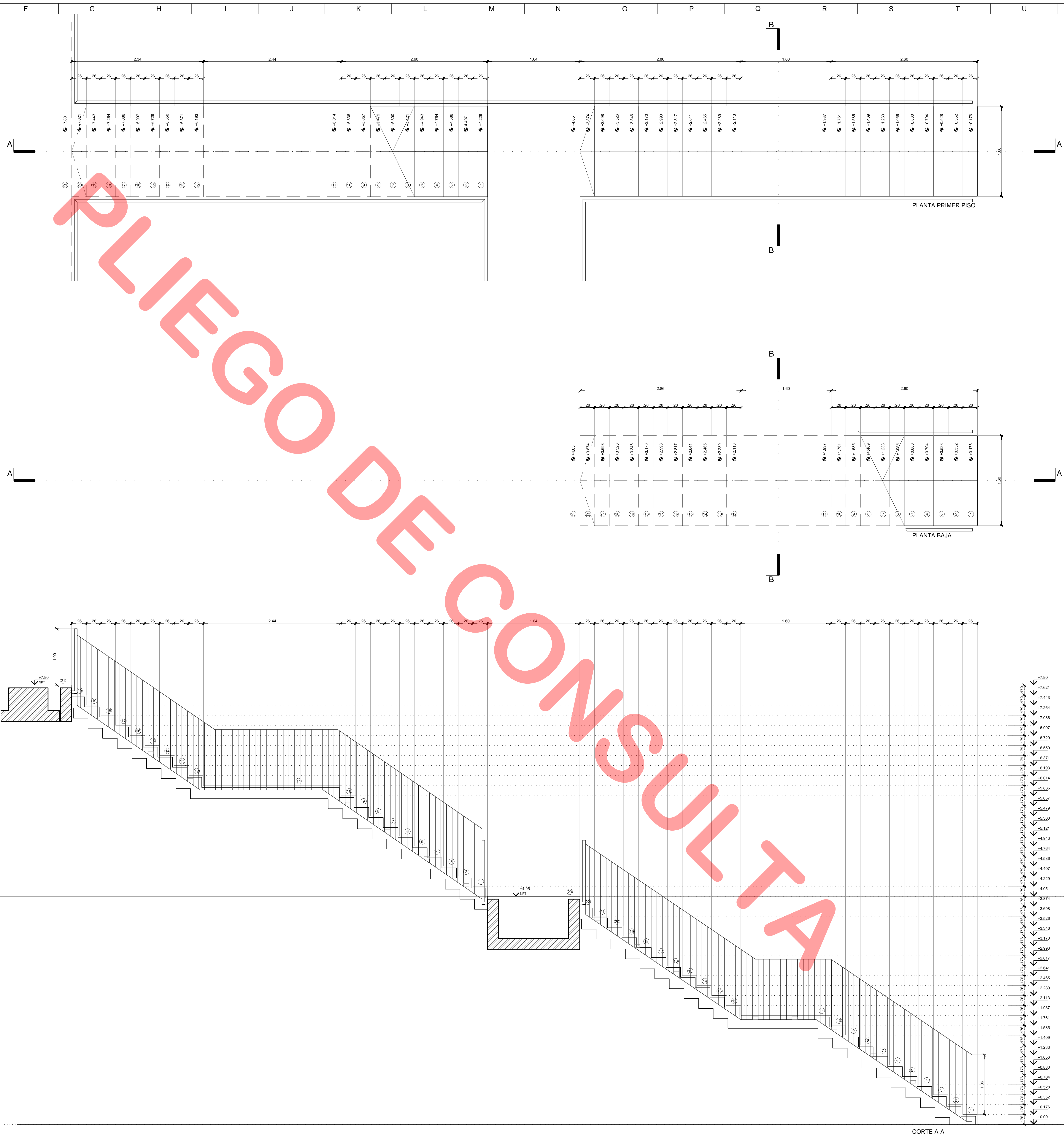

PROPIETARIO  
**PODER JUDICIAL DE RIO NEGRO**  
**CJCC CIPOLLETTI**

MODIFICACIONES	
REV.	DESCRIPCION
D	A A A
A	A A A
A	A A A
A	A A A
A	A A A
A	A A A
A	A A A
A	A A A
A	A A A
A	A A A
A	A A A

PROYECTO  
 CHERRENCO-COHAS-TYSBEROWICZ-VIGHORI  
 arquitectos

DIBUJO	CONTRUO
AS	JU

DESCRIPCION  
**DETALLE DE ESCALERA HALL ACCESO**

ESTE DOCUMENTO CONTIENE INFORMACION DE PROPIEDAD DE CJCC. SU REPRODUCCION TOTAL O PARCIAL, SIN NUESTRA AUTORIZACION ESCRITA ESTA PROHIBIDA.

Rev.	Revisión	Revisión
00	A	PARA LICITACION

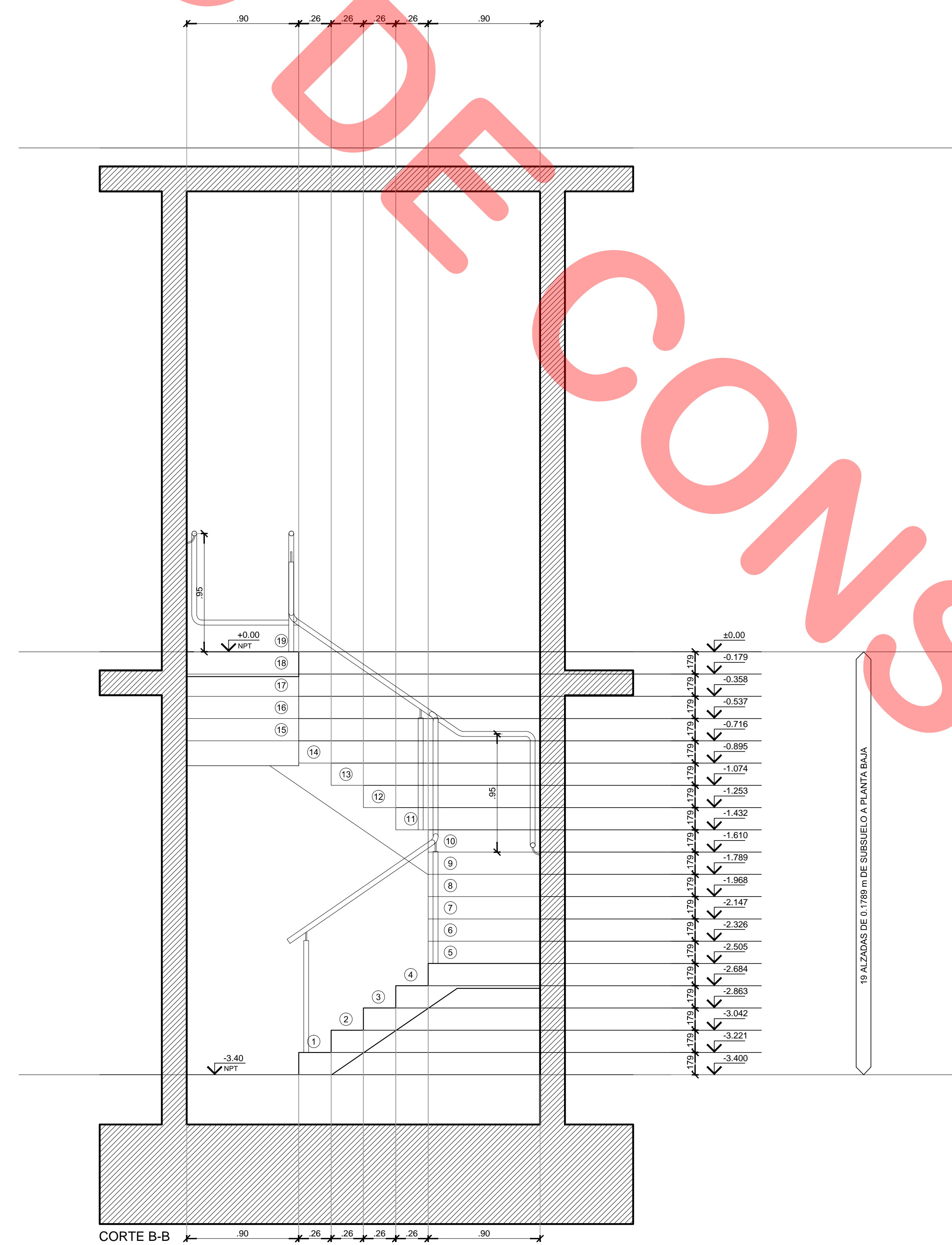
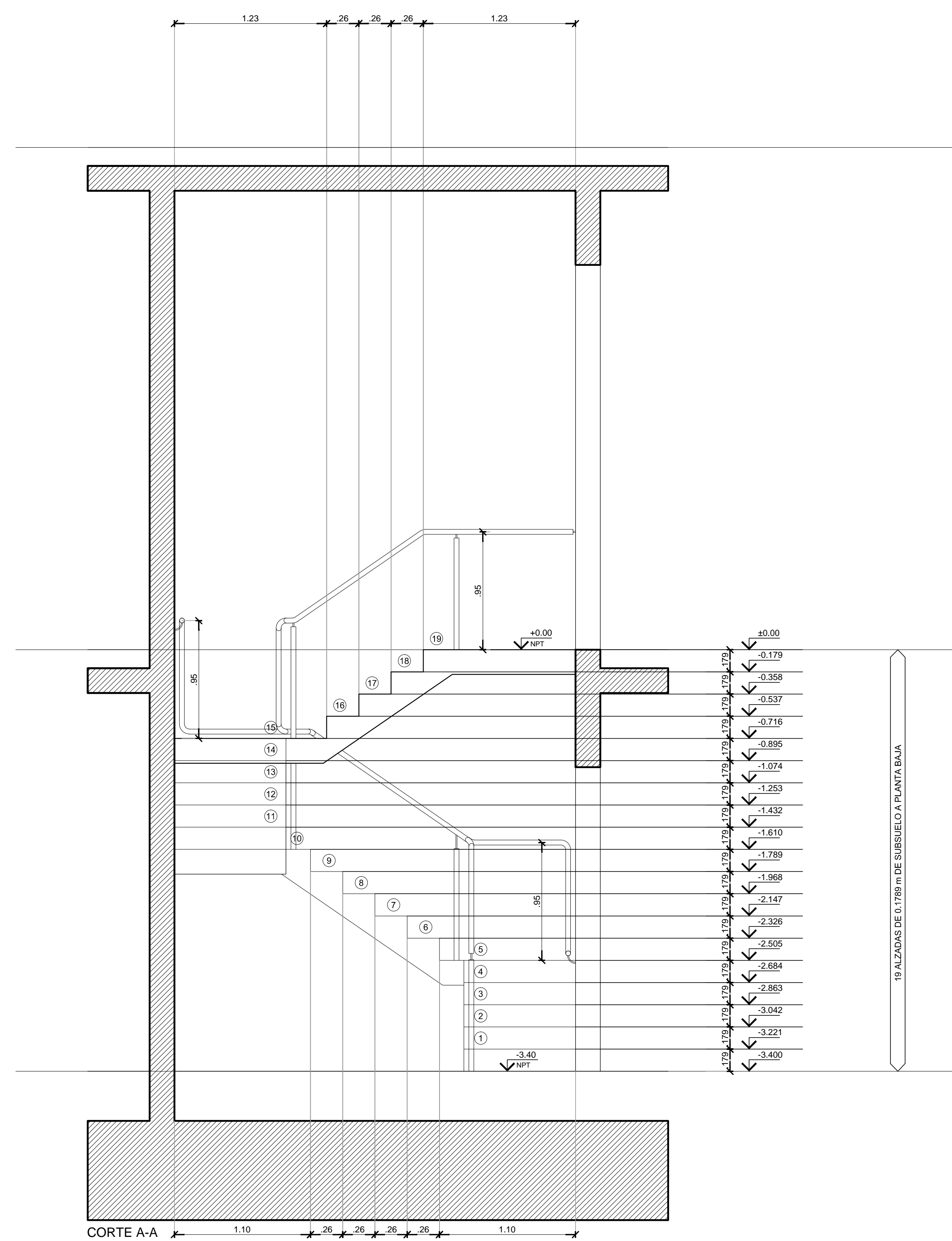
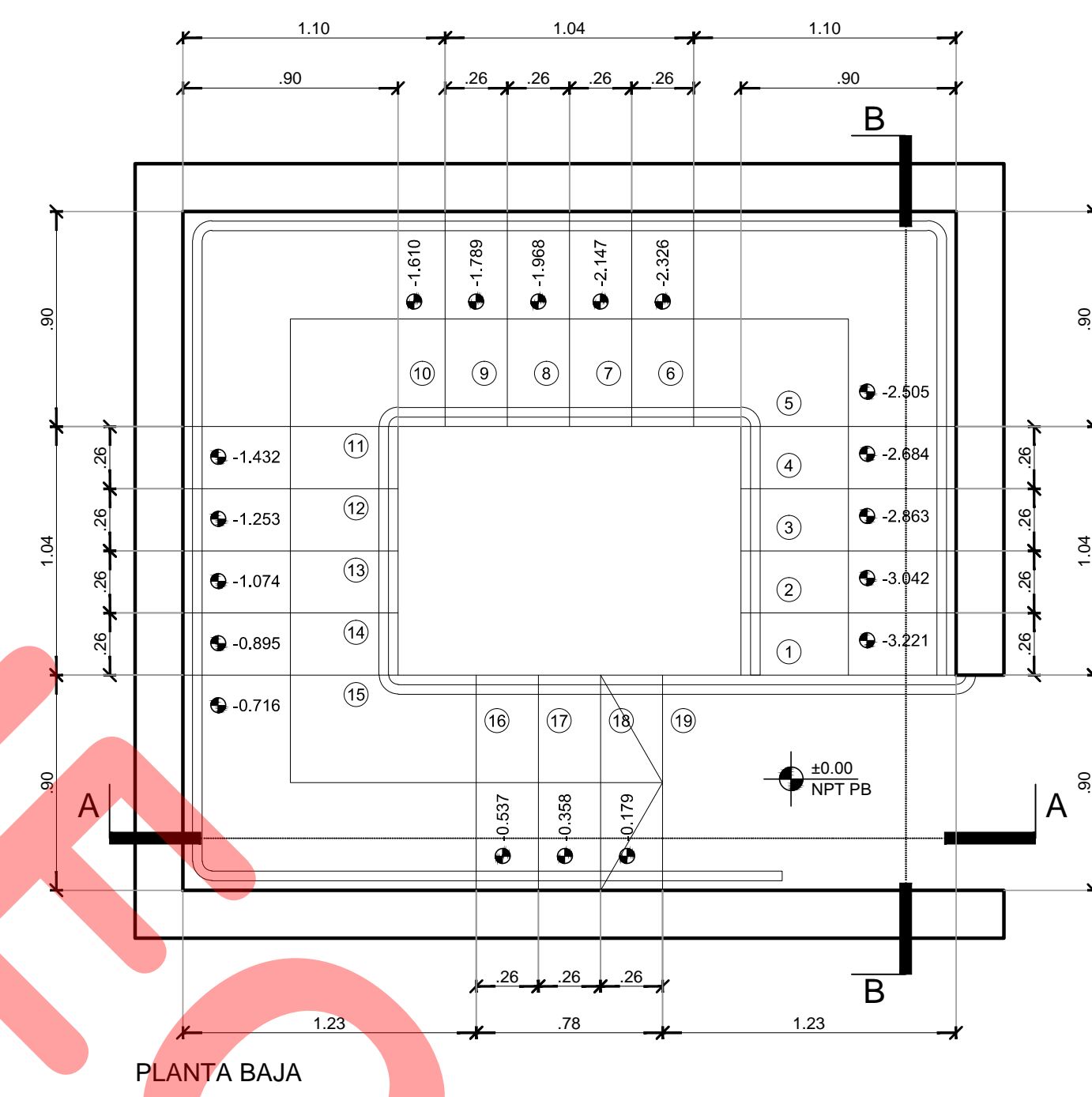
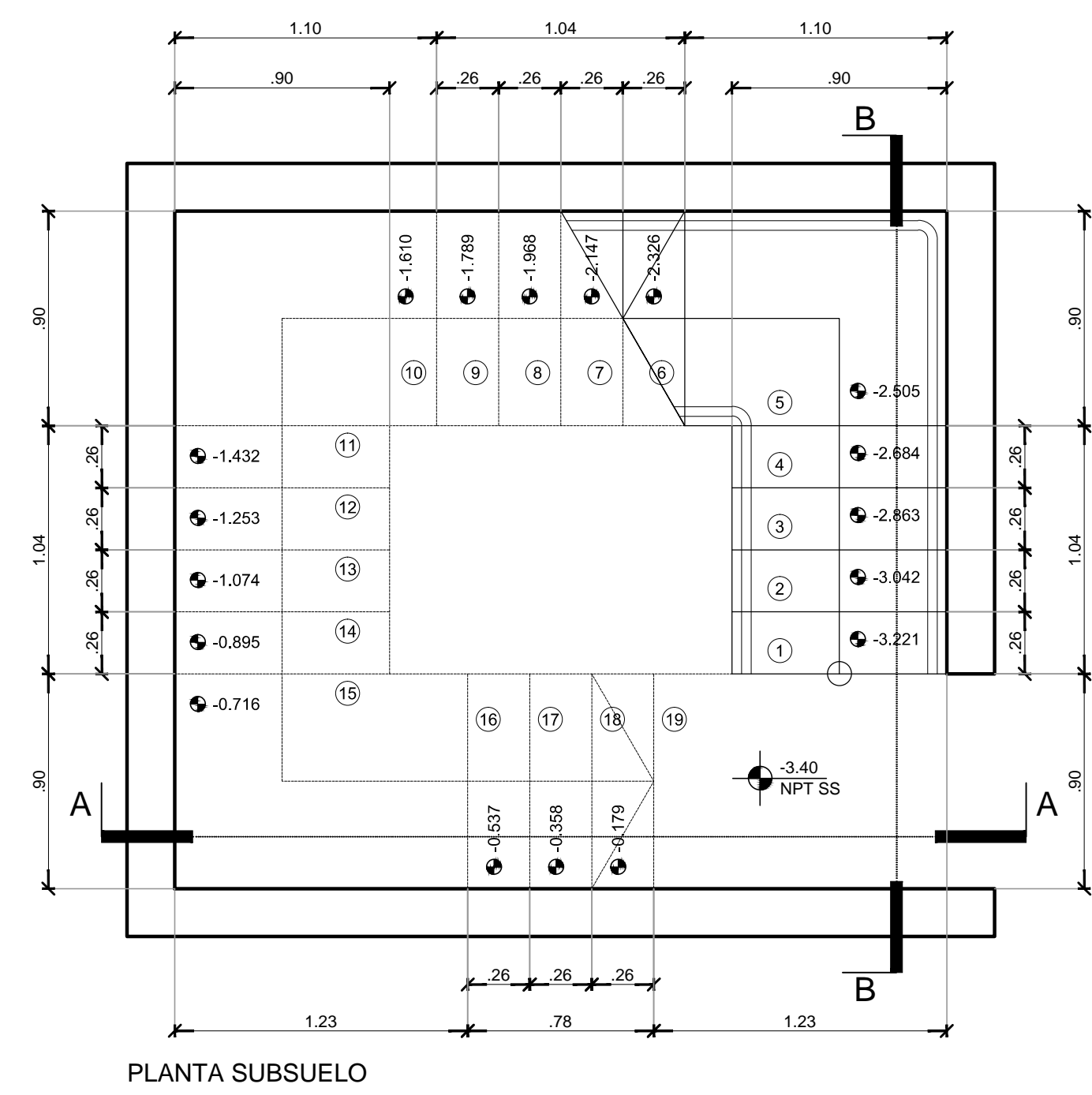

PROYECTO	CHERRENCO-COHAS-TYSEROWICZ-VIGHONI
FECHA	11 de septiembre 2008
ARQUITECTOS	CHERRENCO-COHAS-TYSEROWICZ-VIGHONI

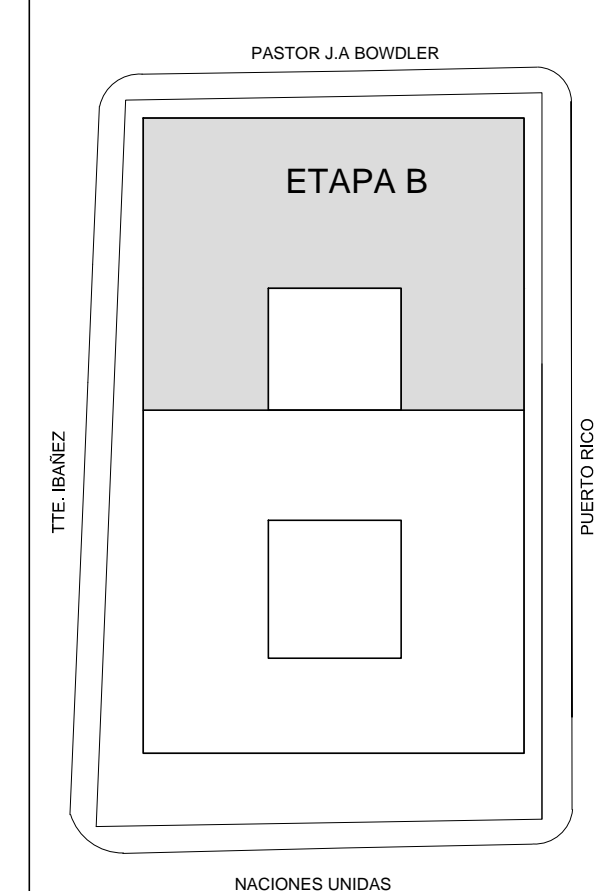
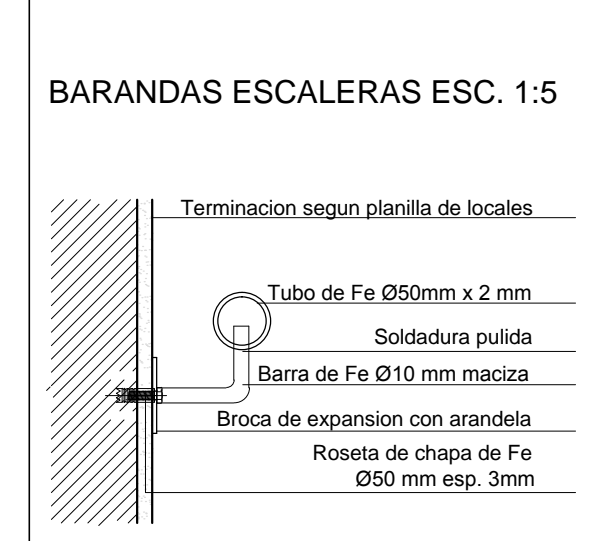
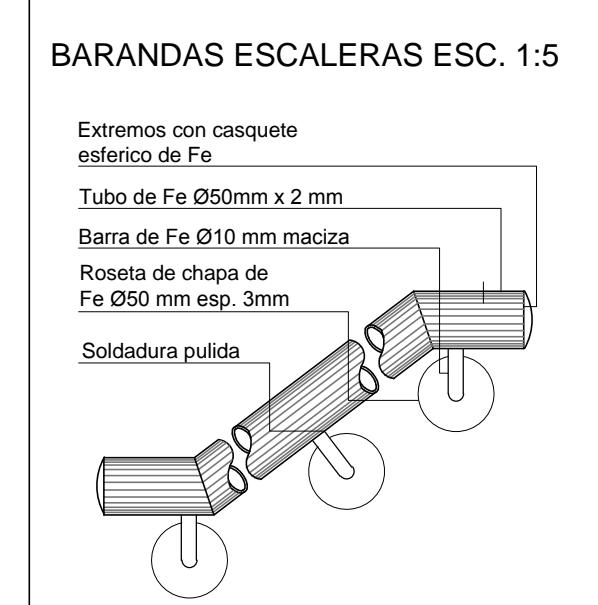
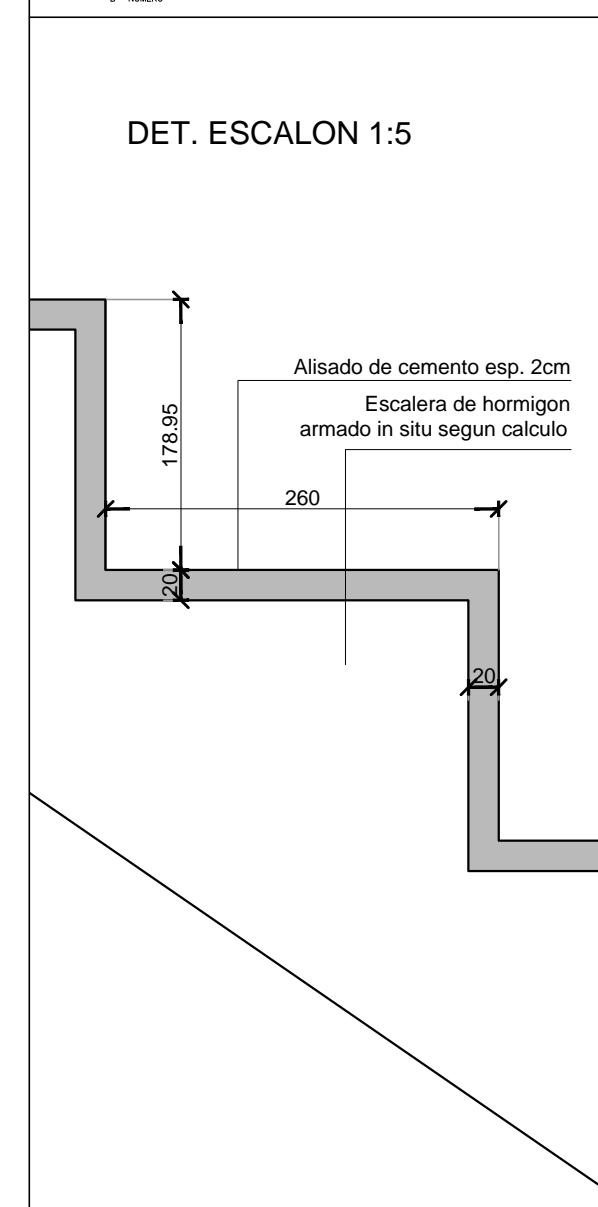

PROPIETARIO  
**PODER JUDICIAL DE RIO NEGRO**  
**CJCC CIPOLLETTI**

REV.	FECHA	DESCRIPCION
D	A	A
A	A	A
A	A	A
A	A	A
A	A	A
A	A	A
A	A	A
A	A	A
A	A	A
A	A	A

PROYECTO  
 CHERRENCO-COHAS-TYSEROWICZ-VIGHONI  
 arquitectos  
 11 de septiembre 2008 of. C14384/F - Ciudad de Buenos Aires, Argentina  
 TEL: 011 4790 2665

DIBUJO: AS CONTROLADO: JU  
 FECHA: 24.09.15 ESCALA: 1:25

DESCRIPCION  
**DETALLE DE ESCALERA DETENIDOS**

ESTE DOCUMENTO CONTIENE INFORMACION DE PROPIEDAD DE CJCC. SU REPRODUCCION TOTAL O PARCIAL, SIN NUESTRA APROBACION ESCRITA ESTA PROHIBIDA.

00	A	PARA LICITACION
CJCC	DE	ESC-02







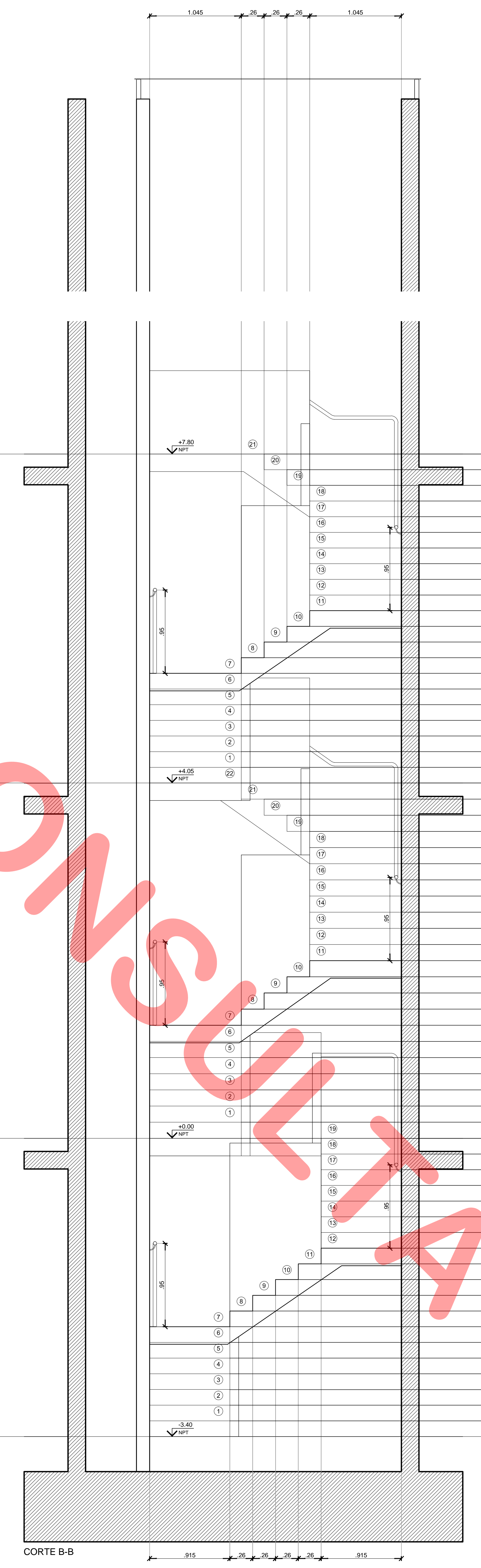
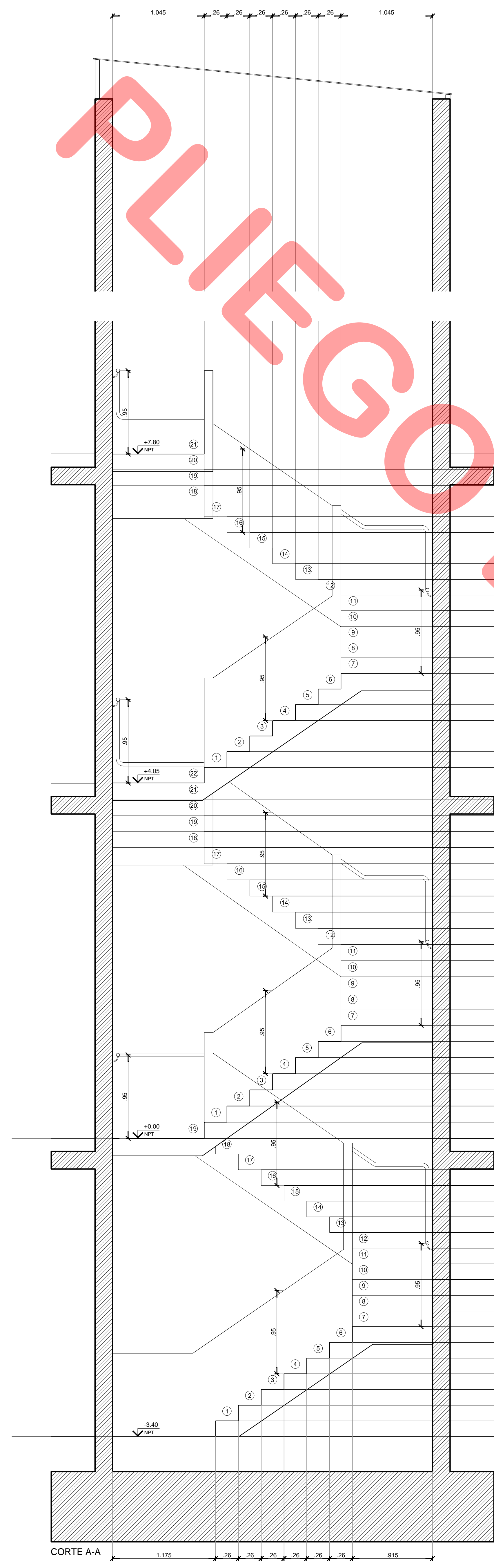
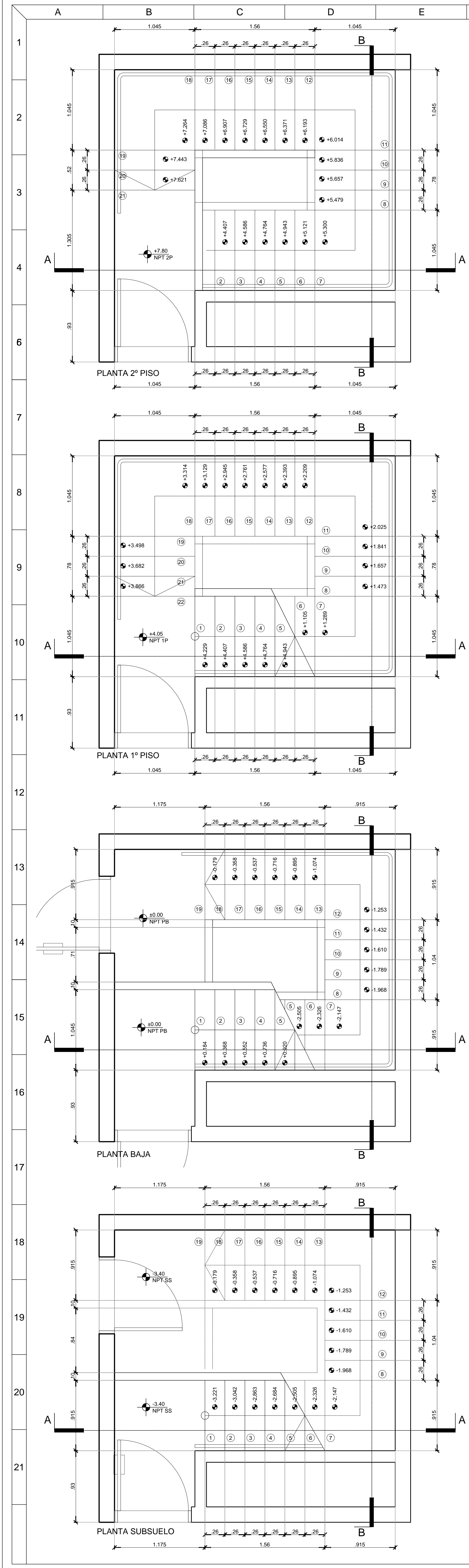

CANT.: 02  
(1 COMO EL DIBUJO, 1 ESPEJADA)

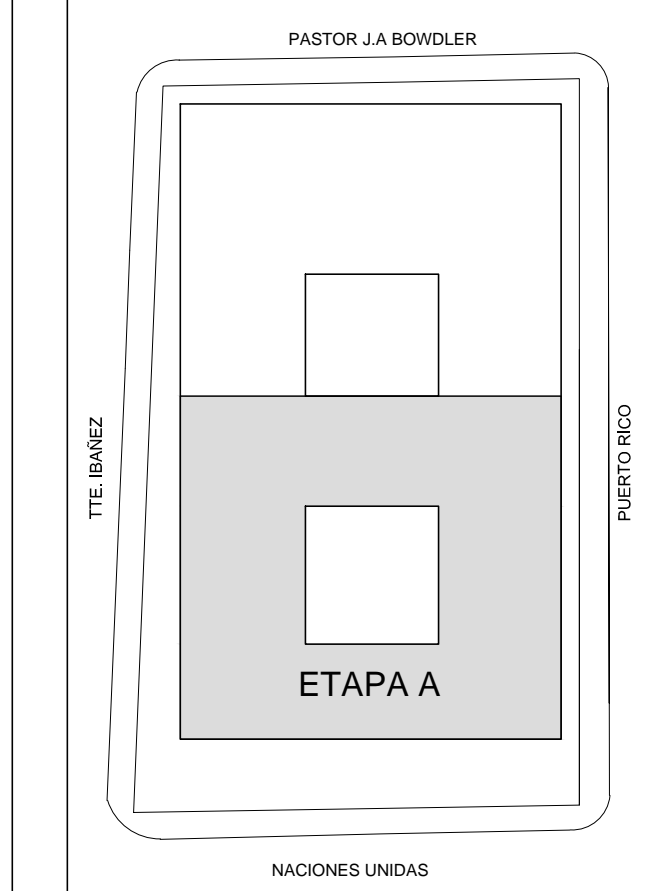
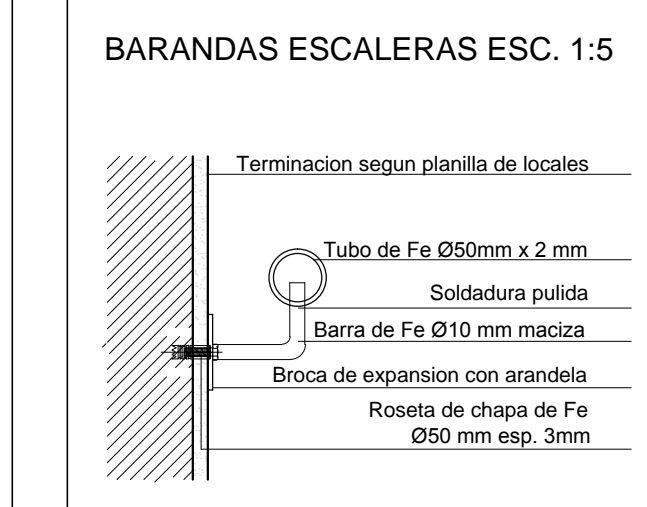
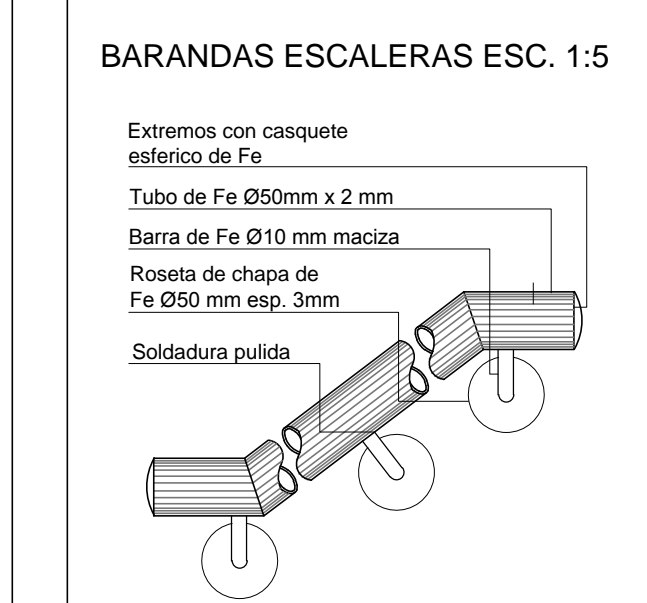
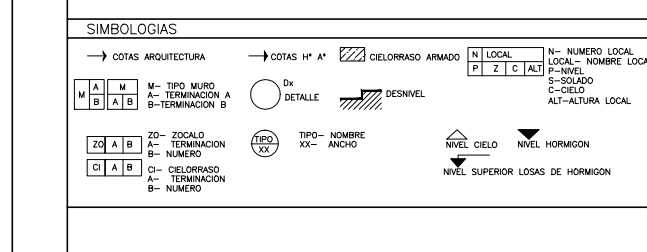

PROPIETARIO  
PODER JUDICIAL  
DE RIO NEGRO

CJCC  
CIPOLLETTI

MODIFICACIONES

REV	FECHA	DESCRIPCION
D	A	A
A	A	A
A	A	A
A	A	A
A	A	A
A	A	A
A	A	A
A	A	A
A	A	A
A	A	A
A	A	A

PROYECTO  
CHERRINCO-COMAS Y ZEBROWICZ-VICHONI  
arquitectos

11 de septiembre 2006 of 1 C1484F - Ciudad de Buenos Aires, Argentina  
Tel: 011 4760-2000  
e-mail: cherrinco@gnol.com

DIBUJO: A3 CONTROLLO: A3  
FECHA: 24.09.15 ESCALA: 1:25

DESCRIPCION  
DETALLE DE ESCALERA  
NUCLEOS A Y B

ESTE DOCUMENTO CONTIENE INFORMACION DE PROPIEDAD DE  
CJCC. SU REPRODUCCION TOTAL O PARCIAL, SIN NUESTRA  
APROBACION ESCRITA ESTA PROHIBIDA.

00 A PARA LICITACION

CJCC DE ESC-06

CANT.: 02  
(1 COMO EL DIBUJO, 1 ESPEJADA)

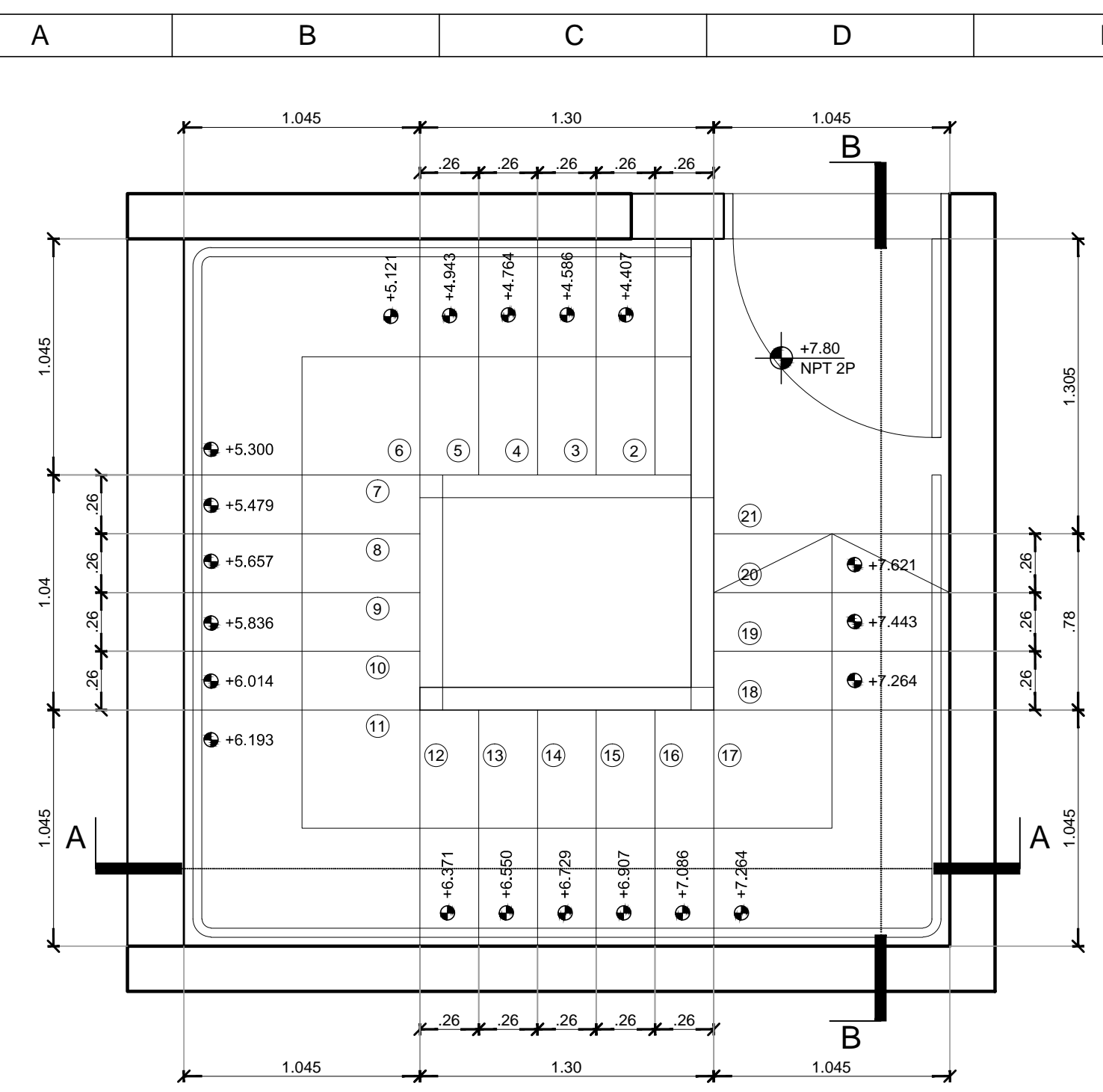

PLANTA 2º PISO

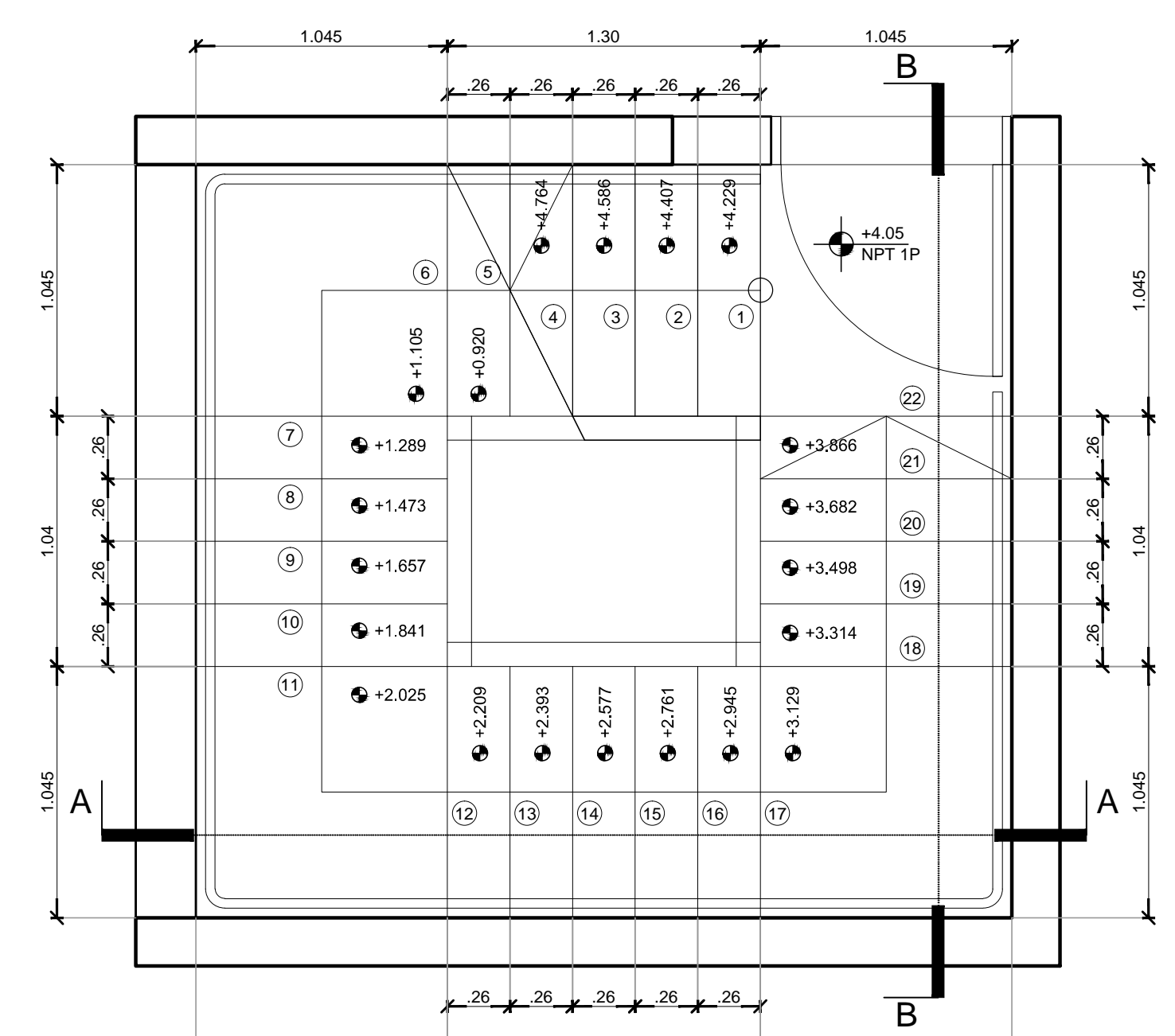



REFERENCIAS			
<b>SANITARIOS</b>			
SA1	Inodoro corto línea Antracita de Ferum		
SA2	Baño Cuadra de Ferum		
SA3	Mingitorio Mural corto de Ferum		
SA4	Baño Johnson acero E 54		
SA5	Inodoro antiantraz WPM Casagosa Metalurgica		
SA6	Lavatorio antiantraz LPN2-WPM Casagosa Metalurgica		
SD1	Inodoro línea Espacio de Ferum		
SD2	Baño línea Espacio de Ferum		
<b>GRIFERIA</b>			
G1	Módulo FV para inodoros FV PRESSMATIC 0345		
G2	Módulo FV para mingitorios FV ECOMATIC 0362 (H)		
G3	Cantileta automática FV TISSANC 0363 (C)		
G4	Cantileta automática FV PRESSMATIC 0361 (SA)		
G5	Ducha FV ARIZONA 0708 (B)		
G6	FV unimax 0411 (01)		
G7			
<b>ACCESORIOS</b>			
A1	Desagüe según a la masa construida		
A2	Desagüe mingitorio		
AD1	Barra reabitable Ferum con portador y accionador		
AD2	Barra reabitable Ferum BS con VITEBA		
AD3	Espina reabitable Ferum Espacio		
<b>MESADAS</b>			
ME1	Mesada granito gris mara con frontón ingletado y zoclo superior		
<b>MUEBLES</b>			
MU1	Lockers 3 puertas		
MU2	Lockers 4 puertas		
<b>CIELORRASOS</b>			
<b>SOLIDOS</b>			
S1	Piso granito según planta		
<b>REVESTIMIENTOS</b>			
R1	Sanitarios 29.7 x 57.20 modificado blanco		
R1			
<b>EQUIPAMIENTO</b>			
E1	Espacio float firm		
E2	Tabiques divisorios tipo top bar		
E3	Anaile electrositronico DOMEC 2 hornallas		
<b>ZOCALOS</b>			
<b>SOLIAS</b>			
SO1	Puñal T de acero inoxidable 3mm		
<b>LISTELES</b>			
<b>MAMPARAS</b>			
<b>PROPIETARIO</b>			
PODER JUDICIAL DE RIO NEGRO			
CJCC CIPOLLETTI			
<b>MODIFICACIONES</b>			
REV.	FECHA	DESCRIPCION	
D	A	A	
A	A	A	
A	A	A	
A	A	A	
A	A	A	
A	A	A	
A	A	A	
A	A	A	
A	A	A	
A	A	A	
<b>PROYECTO</b>			
CHERREBENCO-COHAUS-TYSBERGOWICZ-VIGHONI arquitectos			
11 de septiembre 2004 de C14384AF-Ciudad de Buenos Aires, Argentina TEL 011 4790 2668			
DIBUJO:	AS	JU	
FECHA:	24.09.15	ESCALA:	1:25
<b>DESCRIPCION</b>			
DETALLES DE LOCAL			
ESTE DOCUMENTO CONTIENE INFORMACION DE PROPIEDAD DE CJCC. SU REPRODUCCION TOTAL O PARCIAL, SIN NUESTRA APROBACION ESCRITA ESTA PROHIBIDA.			
00	A	PARA LICITACION	
CJCC	DL	BA	01

REFERENCIAS	
<b>SANITARIOS</b>	
SA1	Inodoro corto línea Adriática de Femur
SA2	Baño Cuadra de Femur
SA3	Mingitorio línea corto de Femur
SA4	Baño Johnson acero E 54
SA5	Inodoro arven IPN2 WPM Caiguzo Metalurgia
SA6	Lavatorio arven L.PN2 WPM Caiguzo Metalurgia
SD1	Inodoro línea Espado de Femur
SD2	Baño línea Espado de Femur
<b>GRIFERIA</b>	
G1	Valvula PV para inodoros PV PRESIMATIC 0346
G2	Valvula PV para mingitorios PV ECOMATIC 0362 01
G3	Cantina automática PV TIPONAC 0383 007
G4	Cantina automática PV PRESIMATIC 0361 03A
G5	Bucha PV ARIZONA 0196B1
G6	PV arven 0411 01
G7	
<b>ACCESORIOS</b>	
A1	Desague rigido a la vista cromado
A2	Desague mingitorio
AD1	Barrañ robotada Femur con portarollo y accionador
AD2	Barrañ robotada Femur 80 cm. VTEB8
AD3	Espajo robotada Femur Espado
<b>MESADAS</b>	
ME1	Mesada granito gris mara con frenos ingletado y zocalo superior
<b>MUEBLES</b>	
MU1	Loores 3 puertas
MU2	Loores 4 puertas
<b>CIELORRASOS</b>	
<b>SOLIDOS</b>	
S1	San toreno 29.7 x 57.20 modificado blanco
<b>REVESTIMIENTOS</b>	
R1	San toreno 29.7 x 57.20 modificado blanco
<b>EQUIPAMIENTO</b>	
E1	Espajo 60x60cm
E2	Tabiques divisorios tipo top box
E3	Anafo electronico vibracione DOMEC 2 hornatas
<b>ZOCALOS</b>	
<b>SOLIAS</b>	
SO1	Perfil T de acero inoxidable 3mm
<b>LISTELES</b>	
<b>MAMPARAS</b>	

MODIFICACIONES		
REV	FECHA	DESCRIPCION
D	A	A
A	A	A
A	A	A
A	A	A
A	A	A
A	A	A
A	A	A
A	A	A
A	A	A
A	A	A

PROYECTO	
CHERRENO-COHAU-TYSBEROWICZ-VIGHIONE arquitectos	
11 de septiembre 2004 de C14384UF - Ciudad de Buenos Aires, Argentina TEL 011 4790 2668 e-mail: cohauc@grancom.com	
DIBUJO	CONTRÓLO
AS	JU
FECHA:	ESCALA:
24.09.15	1:25
DESCRIPCION	
DETALLES DE LOCAL	

PROPIETARIO	
PODER JUDICIAL DE RIO NEGRO	
CJCC CIPOLLETTI	

MODIFICACIONES		
REV	FECHA	DESCRIPCION
D	A	A
A	A	A
A	A	A
A	A	A
A	A	A
A	A	A
A	A	A
A	A	A
A	A	A
A	A	A

PROYECTO	
CHERRENO-COHAU-TYSBEROWICZ-VIGHIONE arquitectos	
11 de septiembre 2004 de C14384UF - Ciudad de Buenos Aires, Argentina TEL 011 4790 2668 e-mail: cohauc@grancom.com	
DIBUJO	CONTRÓLO
AS	JU
FECHA:	ESCALA:
24.09.15	1:25
DESCRIPCION	
DETALLES DE LOCAL	

PROYECTO	
CHERRENO-COHAU-TYSBEROWICZ-VIGHIONE arquitectos	
11 de septiembre 2004 de C14384UF - Ciudad de Buenos Aires, Argentina TEL 011 4790 2668 e-mail: cohauc@grancom.com	
DIBUJO	CONTRÓLO
AS	JU
FECHA:	ESCALA:
24.09.15	1:25
DESCRIPCION	
DETALLES DE LOCAL	

PROYECTO	
CHERRENO-COHAU-TYSBEROWICZ-VIGHIONE arquitectos	
11 de septiembre 2004 de C14384UF - Ciudad de Buenos Aires, Argentina TEL 011 4790 2668 e-mail: cohauc@grancom.com	
DIBUJO	CONTRÓLO
AS	JU
FECHA:	ESCALA:
24.09.15	1:25
DESCRIPCION	
DETALLES DE LOCAL	

PROYECTO	
CHERRENO-COHAU-TYSBEROWICZ-VIGHIONE arquitectos	
11 de septiembre 2004 de C14384UF - Ciudad de Buenos Aires, Argentina TEL 011 4790 2668 e-mail: cohauc@grancom.com	
DIBUJO	CONTRÓLO
AS	JU
FECHA:	ESCALA:
24.09.15	1:25
DESCRIPCION	
DETALLES DE LOCAL	

PROYECTO	
CHERRENO-COHAU-TYSBEROWICZ-VIGHIONE arquitectos	
11 de septiembre 2004 de C14384UF - Ciudad de Buenos Aires, Argentina TEL 011 4790 2668 e-mail: cohauc@grancom.com	
DIBUJO	CONTRÓLO
AS	JU
FECHA:	ESCALA:
24.09.15	1:25
DESCRIPCION	
DETALLES DE LOCAL	

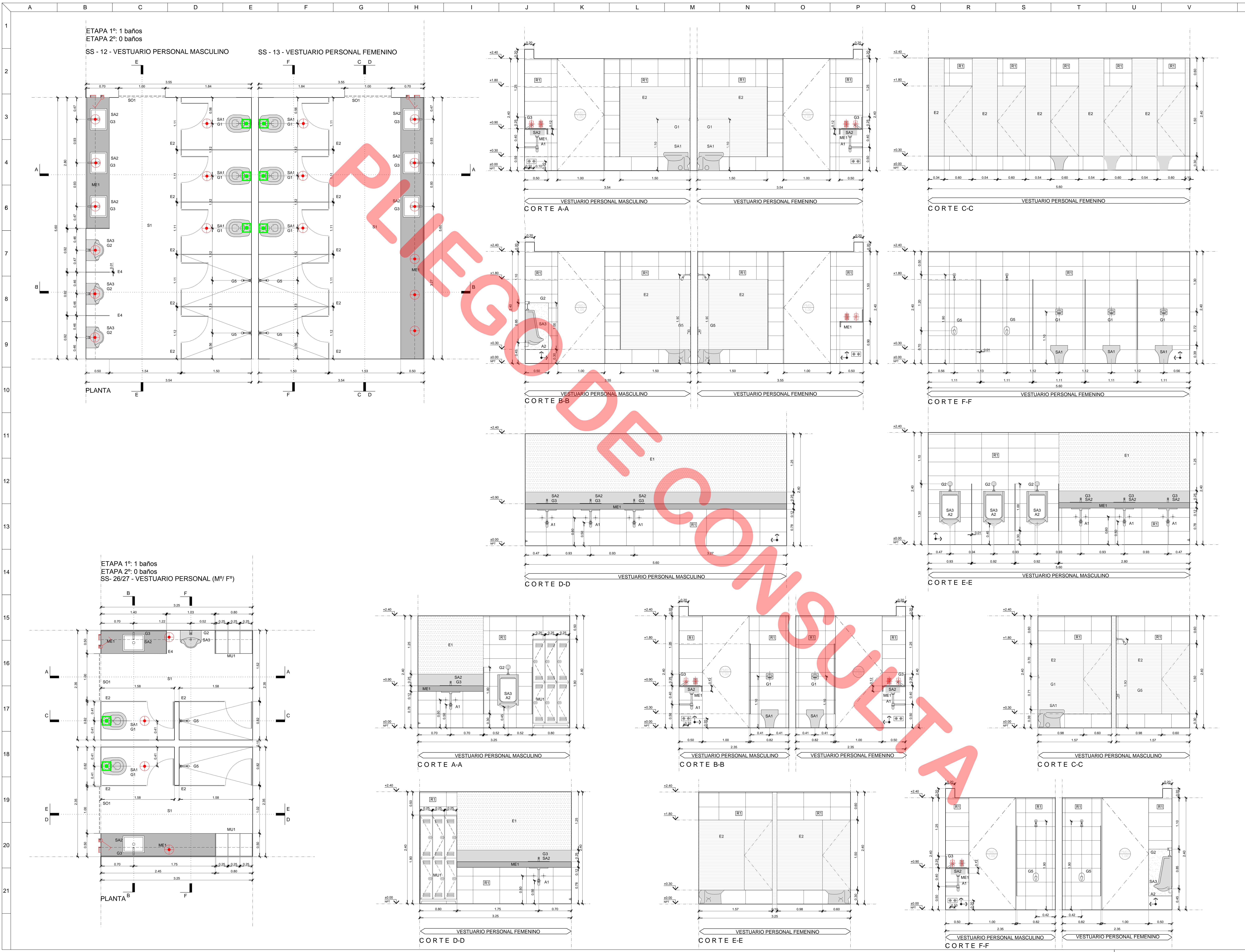

PROYECTO: ...  
 ETAPA 1: ...  
 ETAPA 2: ...

PROYECTO: ...  
 ETAPA 1: ...  
 ETAPA 2: ...

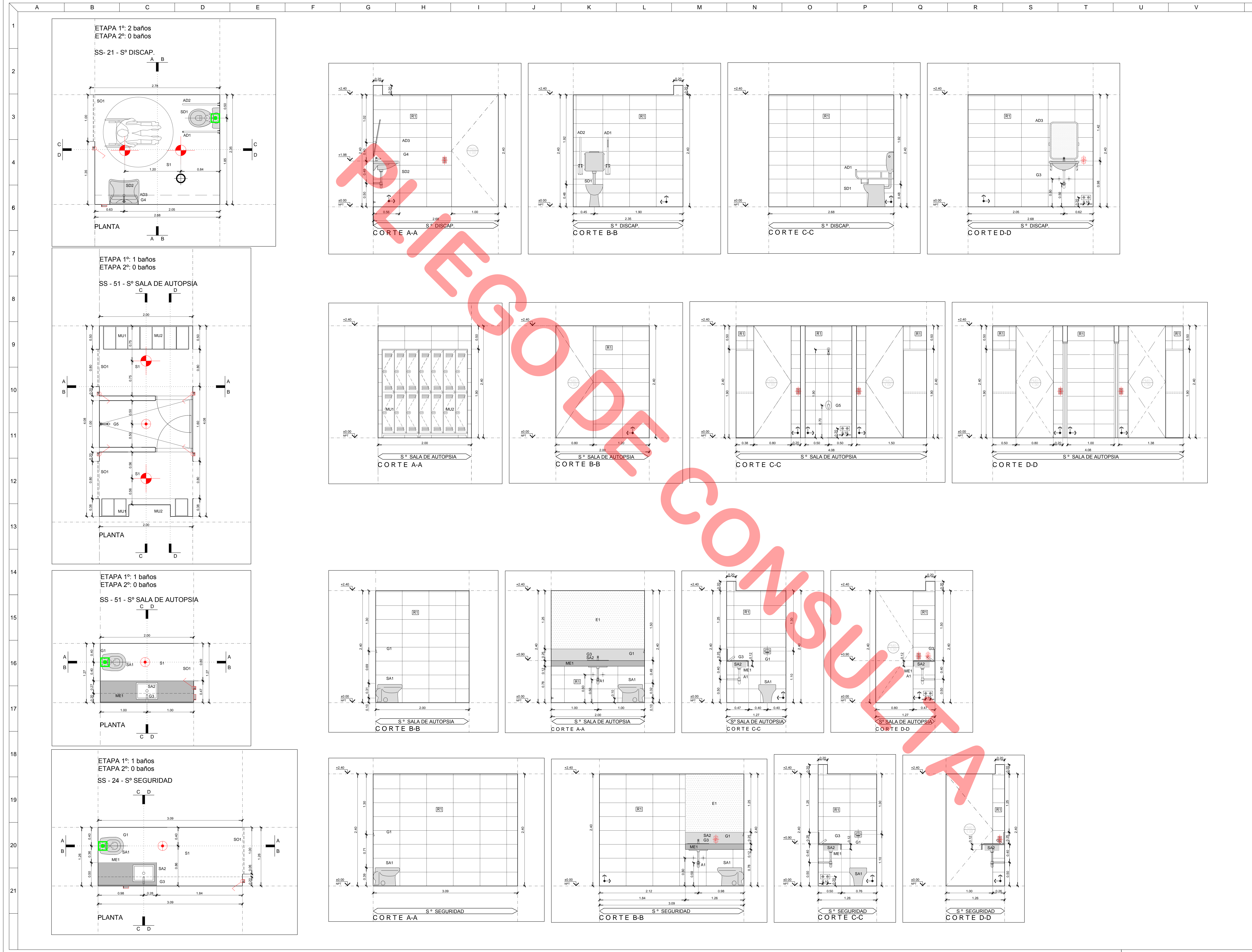

REFERENCIAS																																					
<b>SANITARIOS</b>																																					
SA1	Inodoro corto línea Atlántica de Ferum																																				
SA2	Baño Cuadra de Ferum																																				
SA3	Mingitorio Mural corto de Ferum																																				
SA4	Baño Juhonero línea E 54																																				
SA5	Inodoro giratorio IPN2-WPM Caguazu Metalurgia																																				
SA6	Lavatorio andrón LPN2-WPM Caguazu Metalurgia																																				
SD1	Inodoro línea Espacio de Ferum																																				
SD2	Baño línea Espacio de Ferum																																				
<b>GRIFERIA</b>																																					
G1	Válvula FV para inodoros FV PRESISMATIC 0345																																				
G2	Batiente FV para mingitorios FV ECONOMIC 0362 FV																																				
G3	Canilla automática FV TROPIC 0363 027																																				
G4	Canilla automática FV PRESISMATIC 0361 03A																																				
G5	Ducha FV ARIZONA 010801																																				
G6	FV unisex 0411 01																																				
G7																																					
<b>ACCESORIOS</b>																																					
A1	Desague rígido a la vista cromado																																				
A2	Desague mingitorio																																				
AD1	Barra rebatible Ferum con pomalizador y accionador																																				
AD2	Barra rebatible Ferum 80 cm. VTEB																																				
AD3	Español rebatible Ferum Espacio																																				
<b>MESADAS</b>																																					
ME1	Mesa de granito gris mara con frenes ingletado y zocalo superior																																				
<b>MUEBLES</b>																																					
MU1	Lockers 3 puertas																																				
MU2	Lockers 4 puertas																																				
<b>CIELORRASOS</b>																																					
<b>SOLIDOS</b>																																					
S1	Piso granito según planta																																				
<b>REVESTIMIENTOS</b>																																					
R1	San toreno 29 7 x 57 20 rectificado blanco																																				
R1																																					
<b>EQUIPAMIENTO</b>																																					
E1	Español 60x60 cm																																				
E2	Tanques sanitarios tipo tan box																																				
E3	Análisis electrovibracionario DOME 2 hornatas																																				
<b>ZOCALOS</b>																																					
<b>SOLIAS</b>																																					
SO1	Puffit T de acero inoxidable 3mm																																				
<b>LISTELES</b>																																					
<b>MAMPARAS</b>																																					
<p>PROPIETARIO</p> <p>PODER JUDICIAL DE RIO NEGRO</p> <p>CJCC CIPOLLETTI</p>																																					
<p>MODIFICACIONES</p> <table border="1"> <thead> <tr> <th>REV.</th> <th>FECHA</th> <th>DESCRIPCION</th> </tr> </thead> <tbody> <tr><td>D</td><td>A</td><td>A</td></tr> <tr><td>A</td><td>A</td><td>A</td></tr> <tr><td>A</td><td>A</td><td>A</td></tr> <tr><td>A</td><td>A</td><td>A</td></tr> <tr><td>A</td><td>A</td><td>A</td></tr> <tr><td>A</td><td>A</td><td>A</td></tr> <tr><td>A</td><td>A</td><td>A</td></tr> <tr><td>A</td><td>A</td><td>A</td></tr> <tr><td>A</td><td>A</td><td>A</td></tr> <tr><td>A</td><td>A</td><td>A</td></tr> <tr><td>A</td><td>A</td><td>A</td></tr> </tbody> </table>		REV.	FECHA	DESCRIPCION	D	A	A	A	A	A	A	A	A	A	A	A	A	A	A	A	A	A	A	A	A	A	A	A	A	A	A	A	A	A	A	A	A
REV.	FECHA	DESCRIPCION																																			
D	A	A																																			
A	A	A																																			
A	A	A																																			
A	A	A																																			
A	A	A																																			
A	A	A																																			
A	A	A																																			
A	A	A																																			
A	A	A																																			
A	A	A																																			
A	A	A																																			
<p>PROYECTO</p> <p>CHERREBENCO-COHAL-TYSBEROWICZ-VIGHIONE arquitectos</p> <p>11 de septiembre 2004 of. C14384/F - Ciudad de Buenos Aires, Argentina TEL 011 4780 2665 email: ccohal@grat.com</p>																																					
<p>DIBUJO: AS CONTROLADO: JU</p> <p>FECHA: 24.09.15 ESCALA: 1:25</p>																																					
<p>DESCRIPCION</p> <p>DETALLES DE LOCAL</p>																																					
<p>ESTE DOCUMENTO CONTIENE INFORMACION DE PROPIEDAD DE CJCC. SU REPRODUCCION TOTAL O PARCIAL, SIN NUESTRA APROBACION ESCRITA ESTA PROHIBIDA.</p>																																					
<p>00 A PARA LICITACION</p>																																					
<p>CJCC DL BA 03</p>																																					

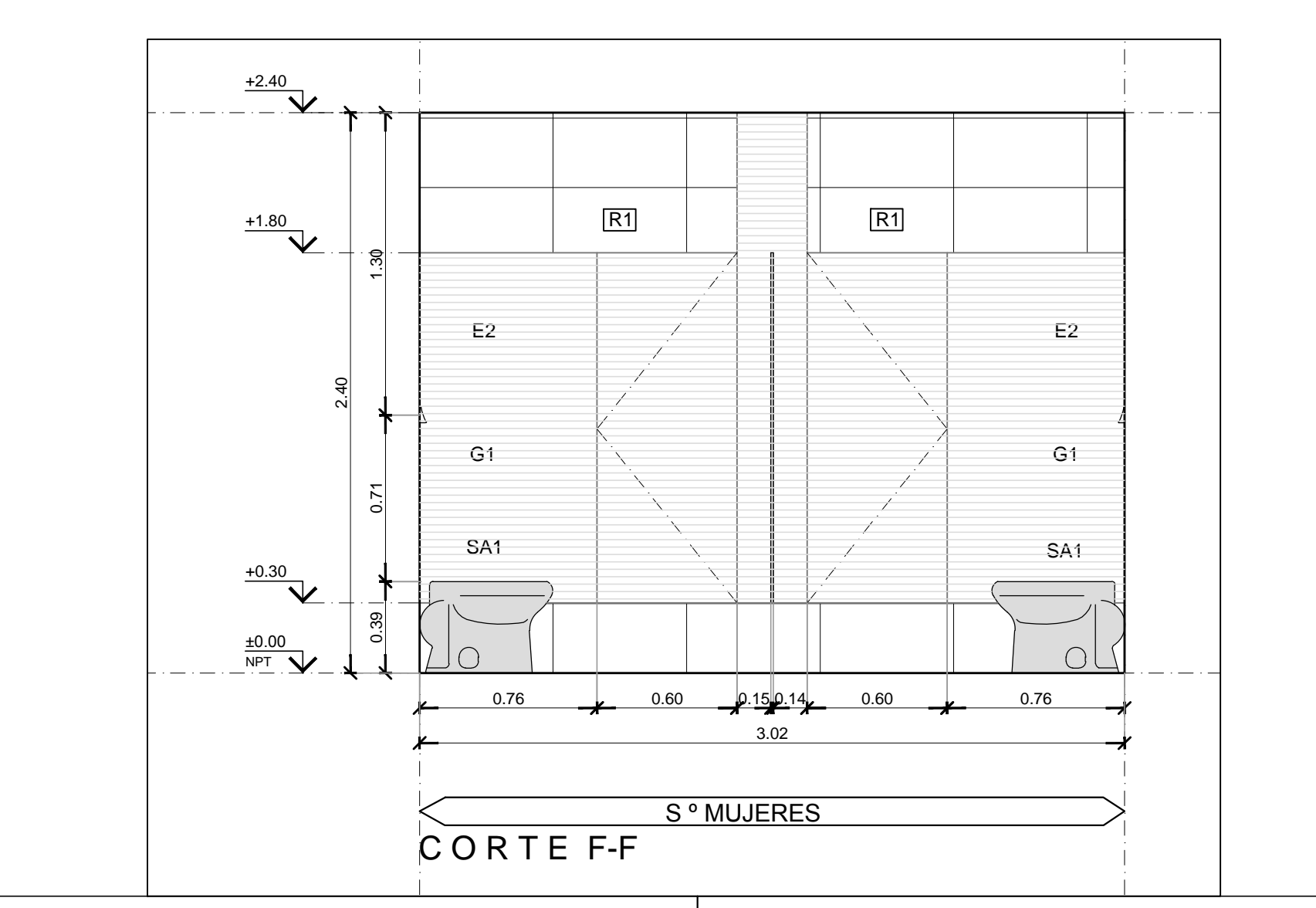
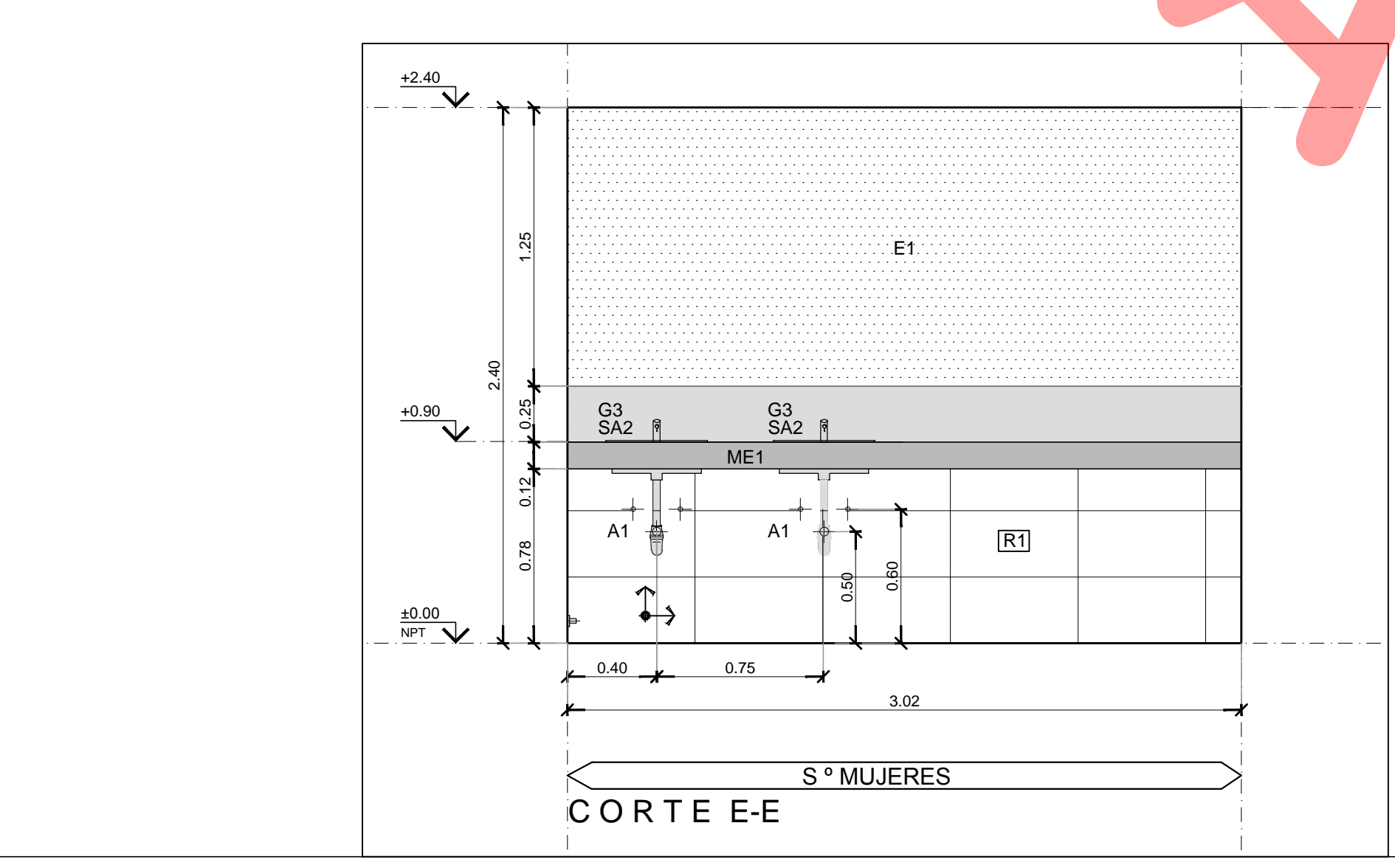
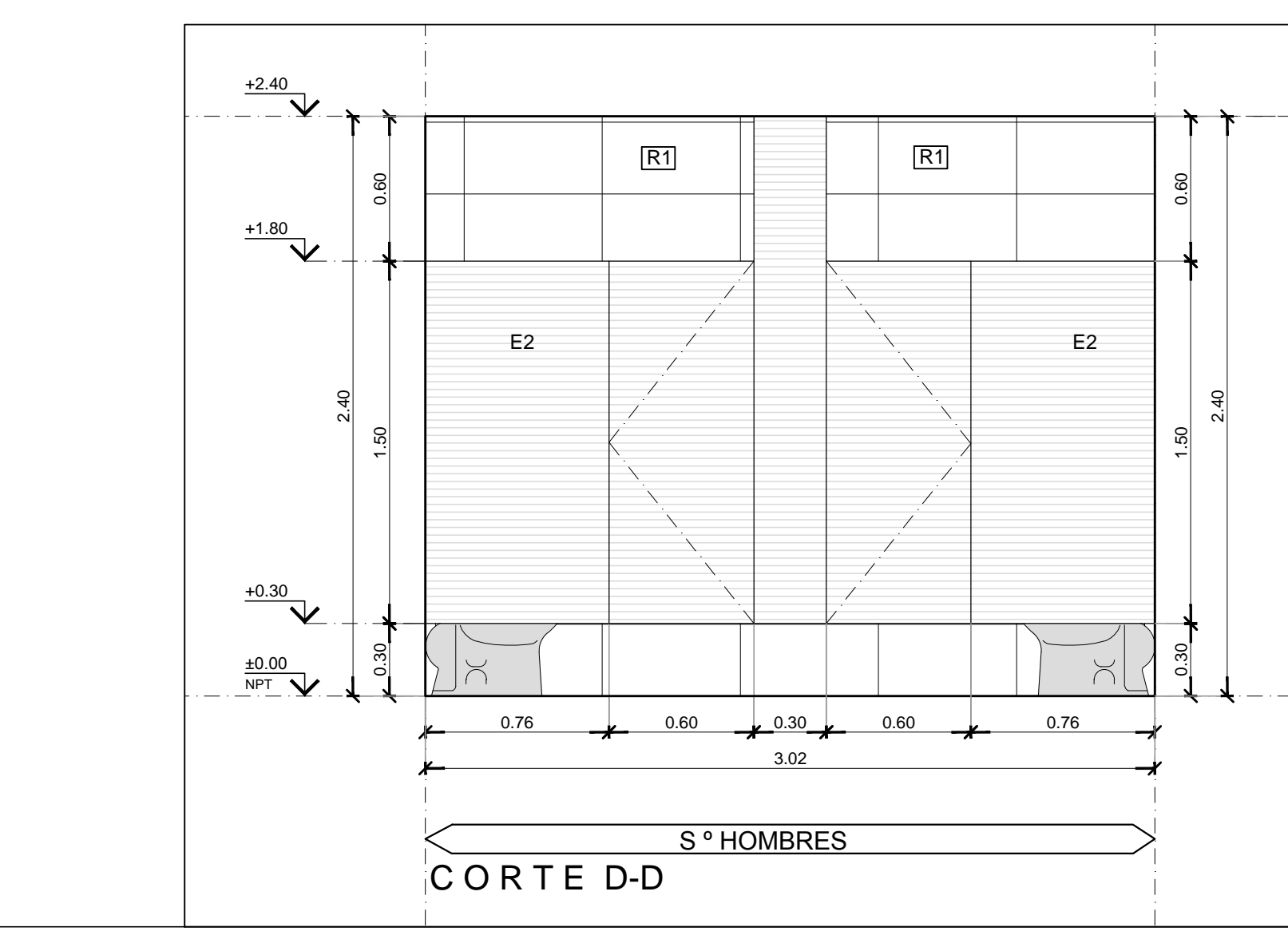
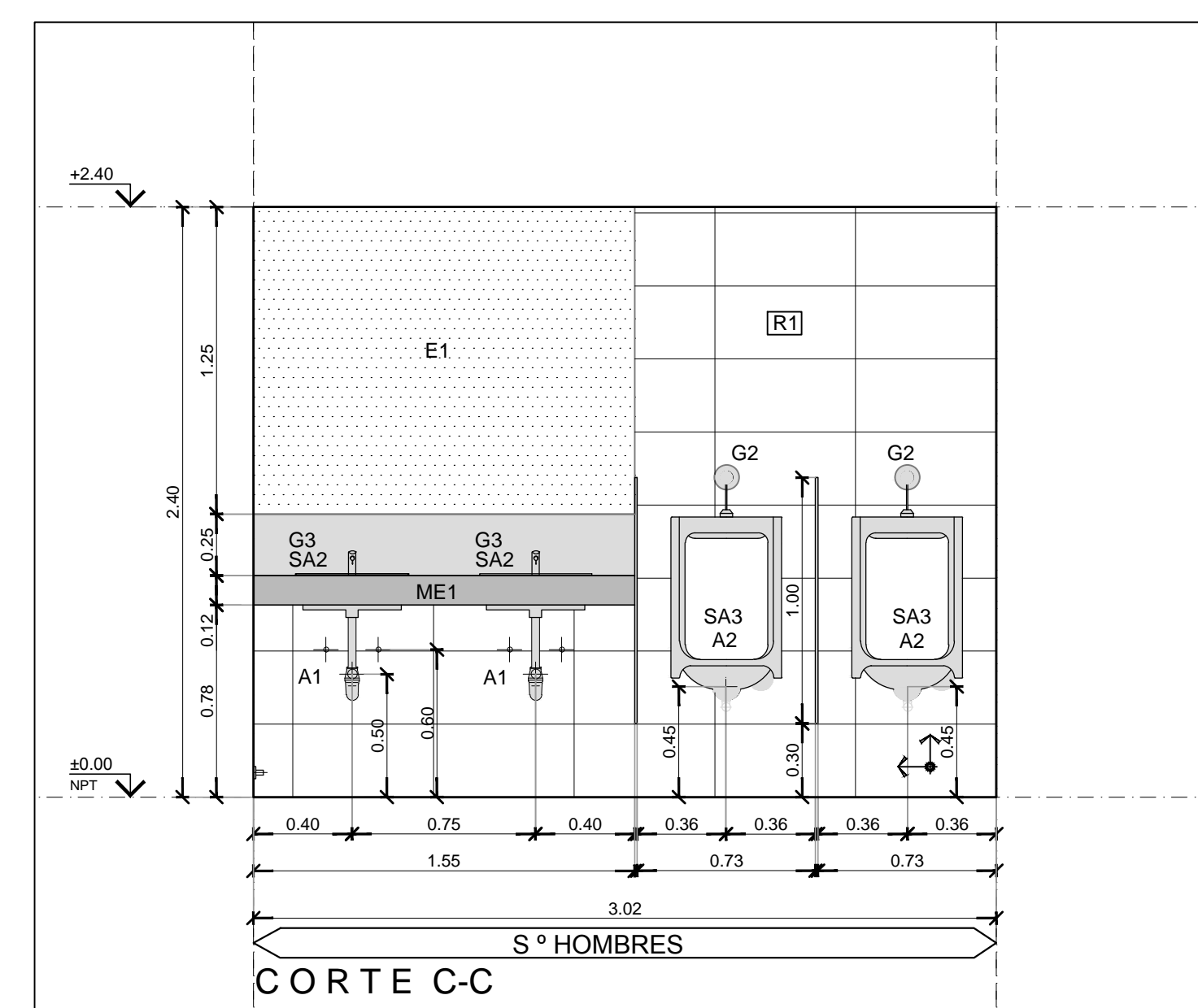
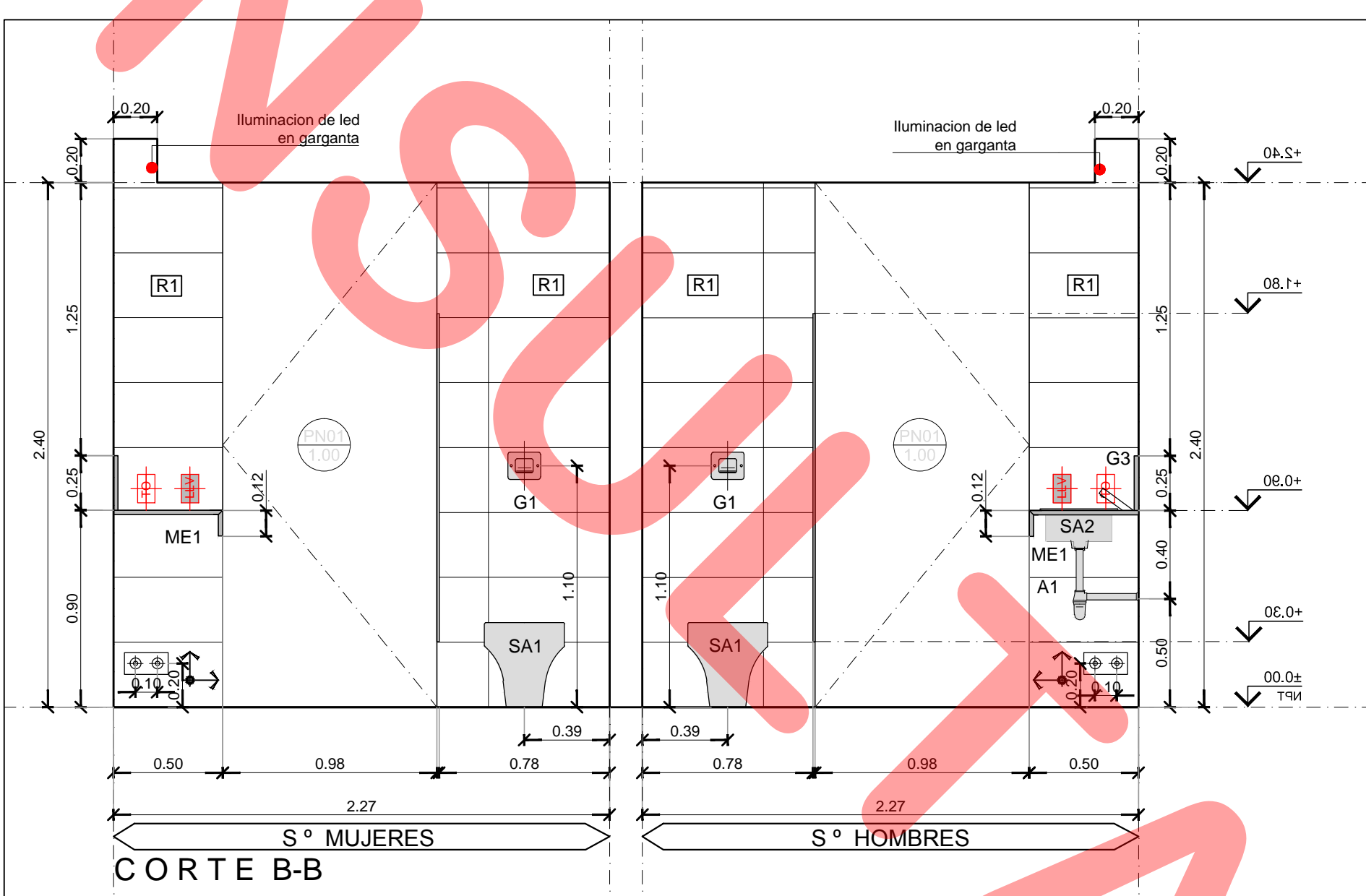
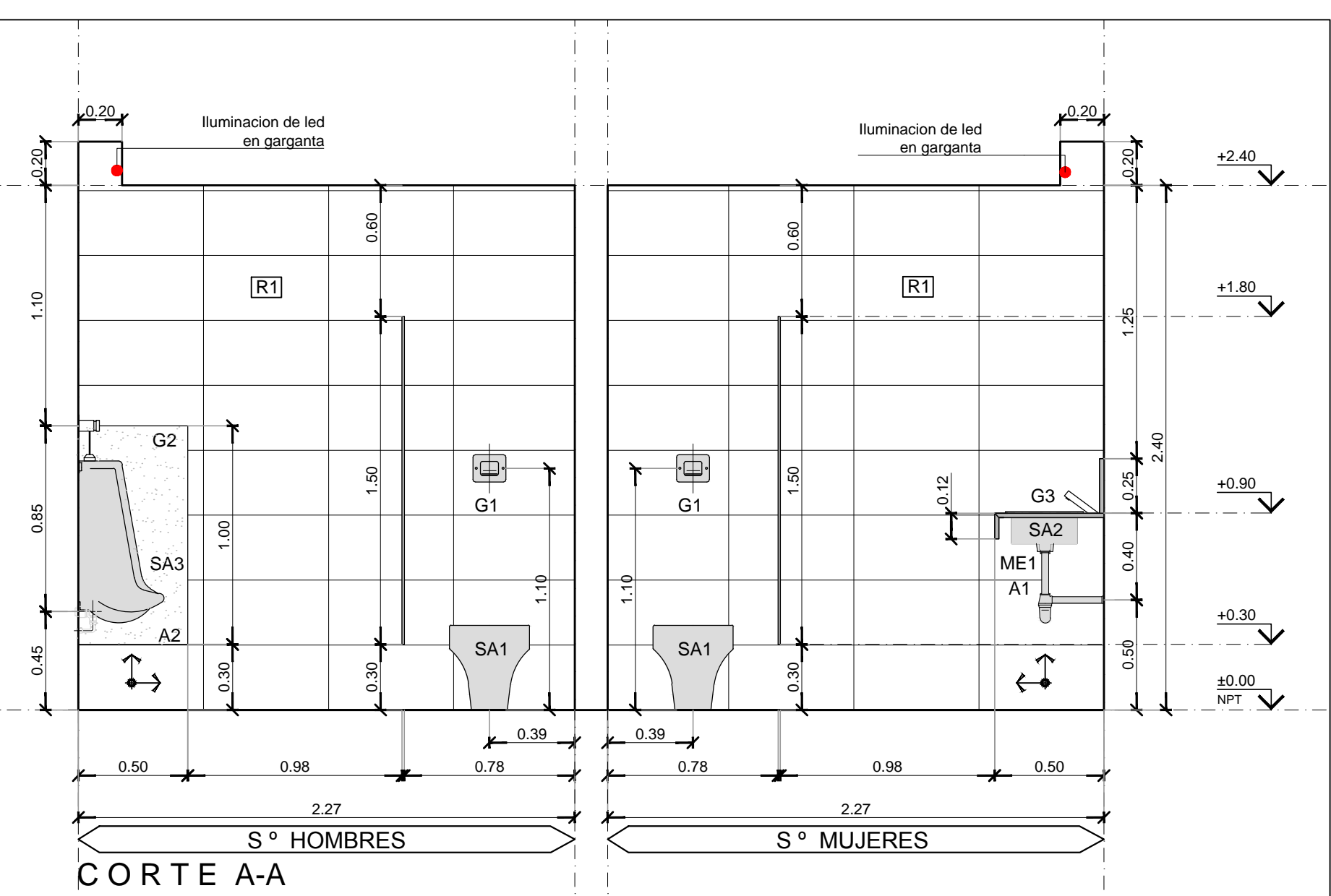
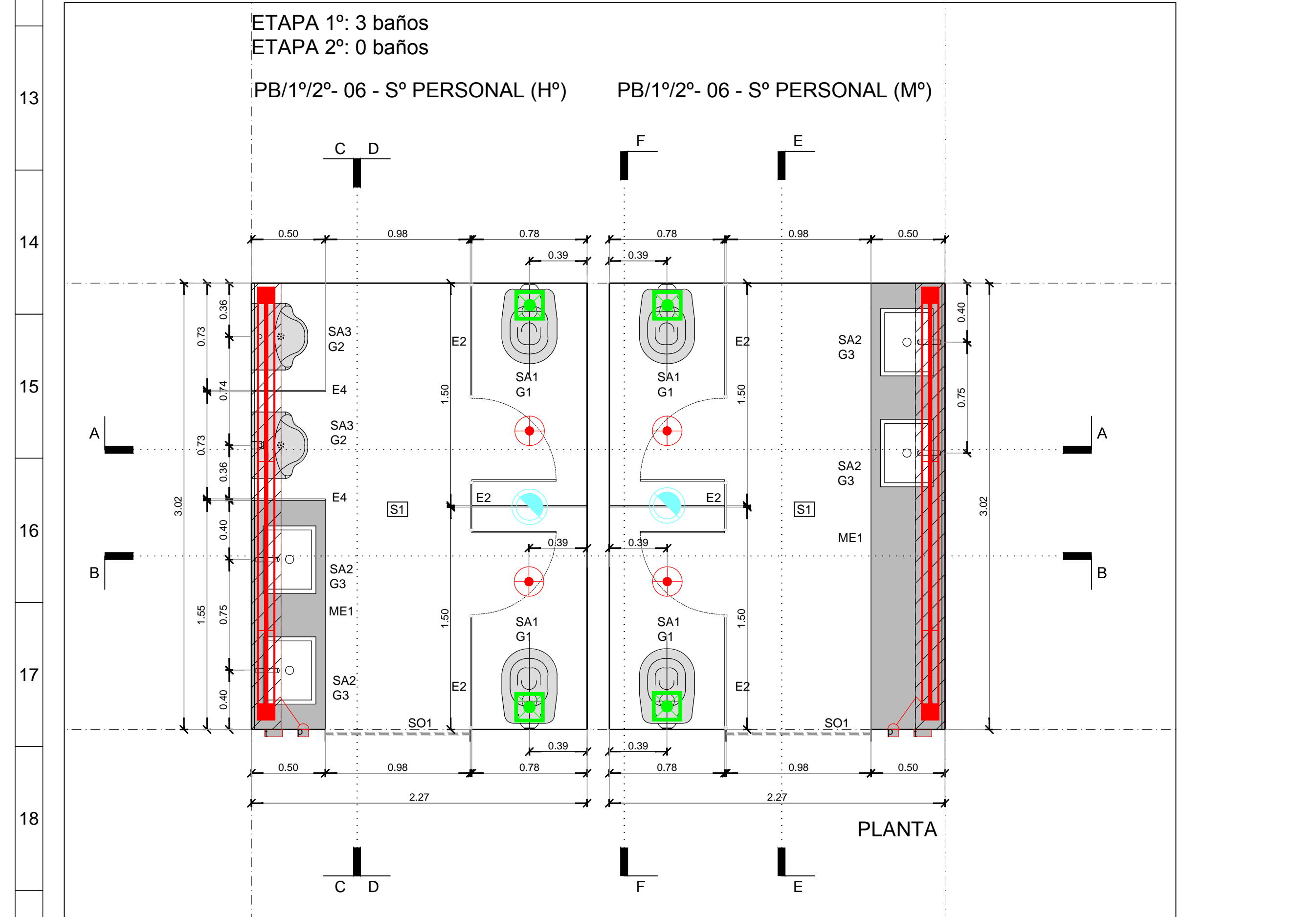
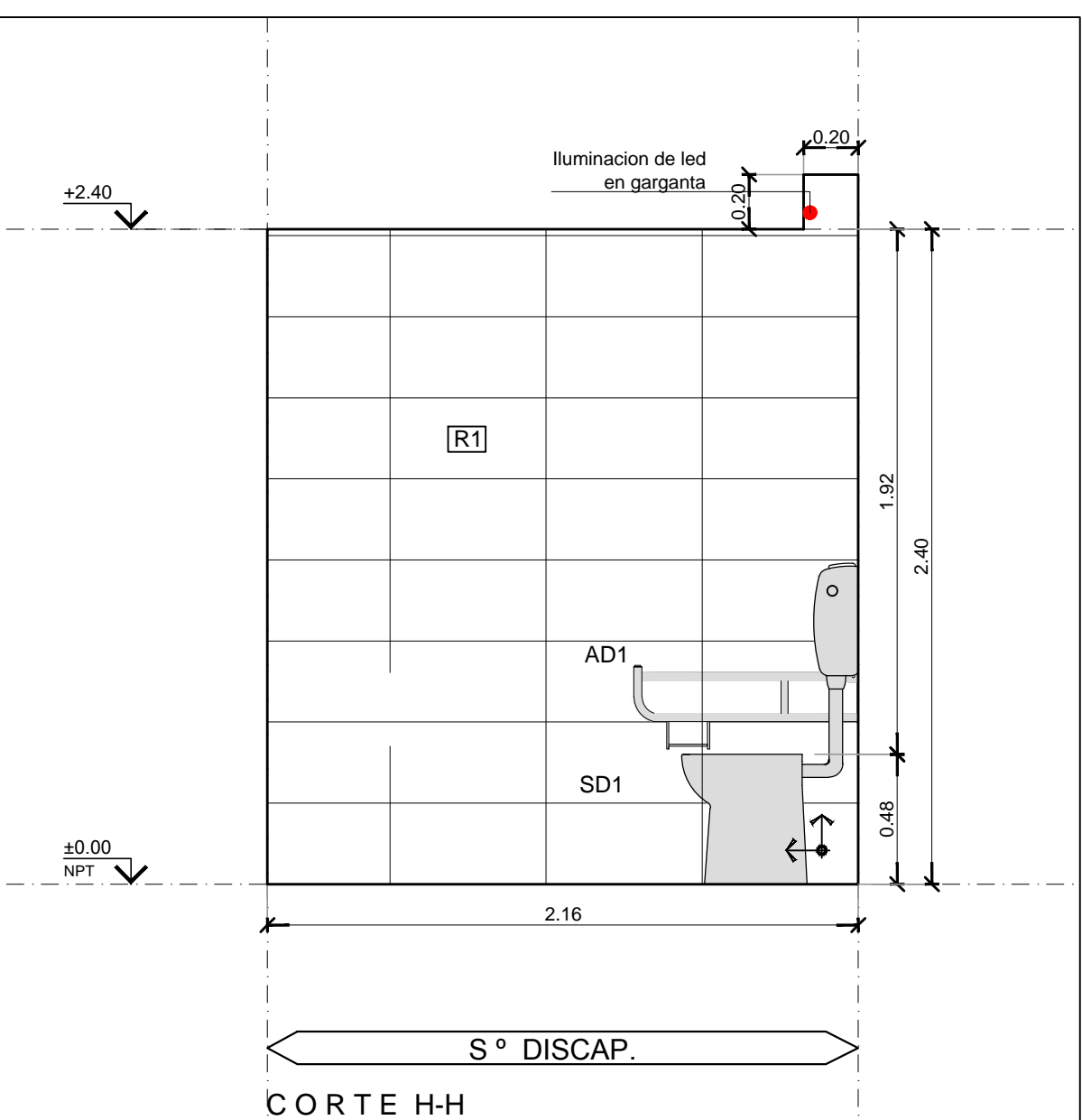
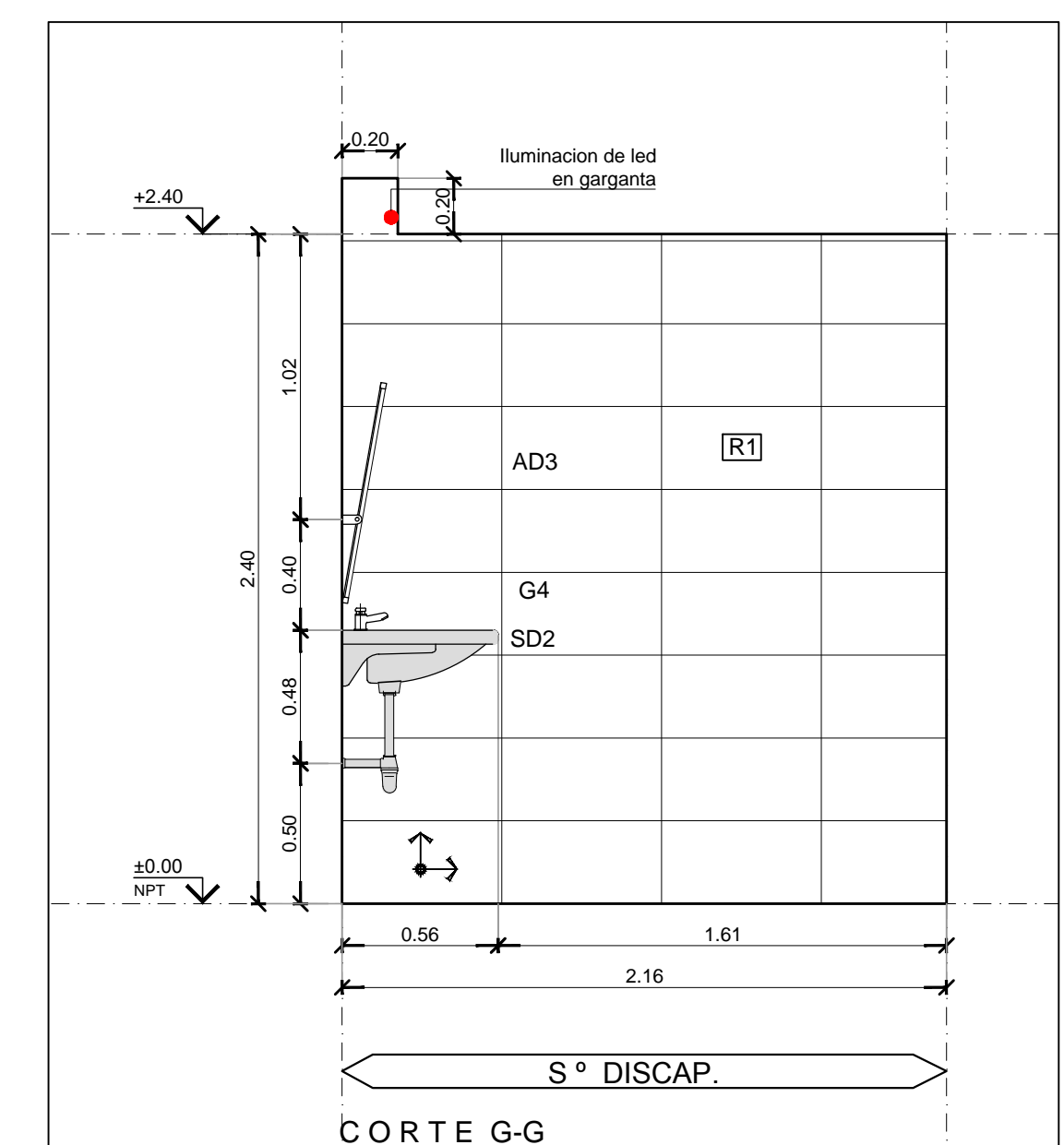
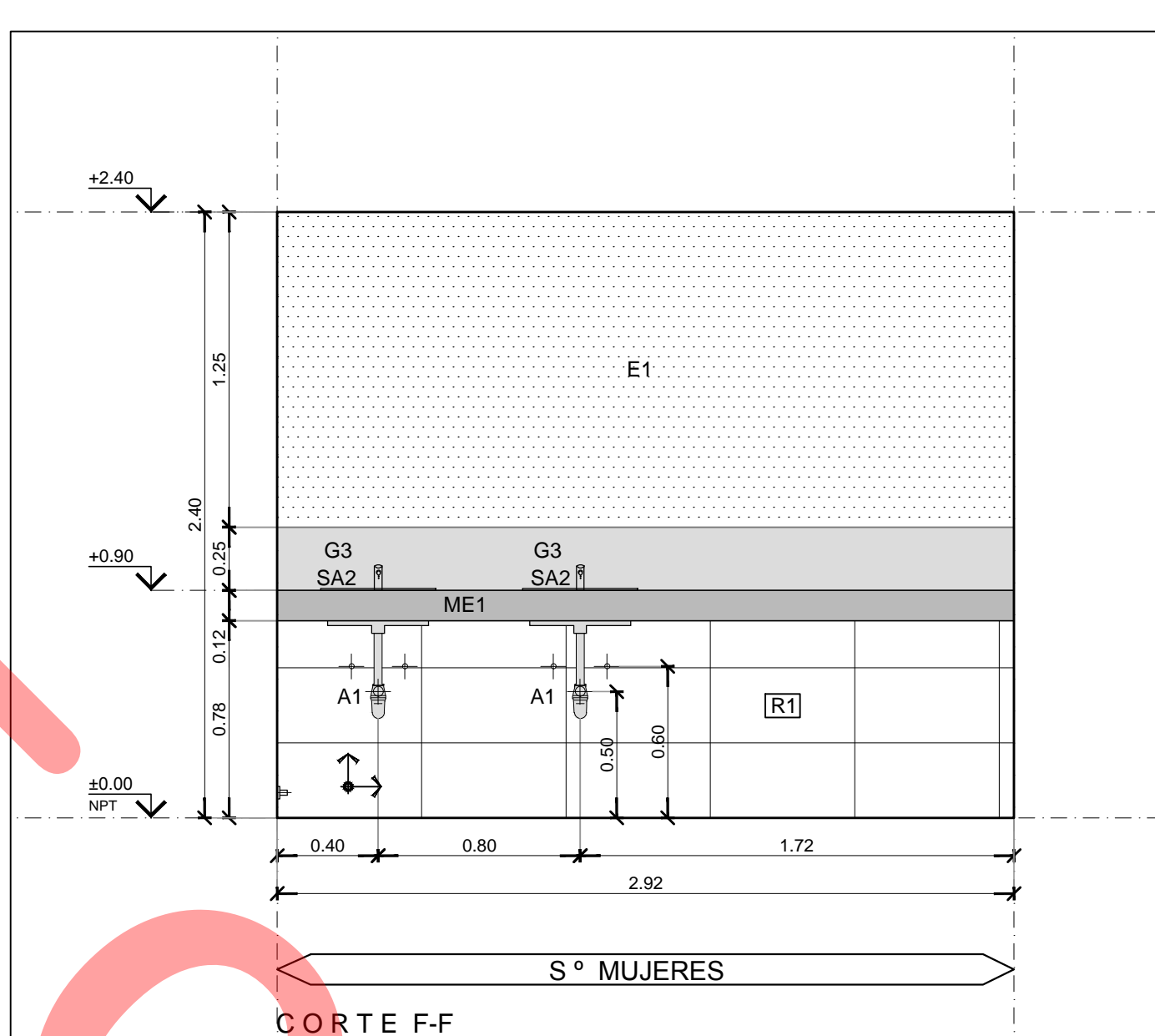
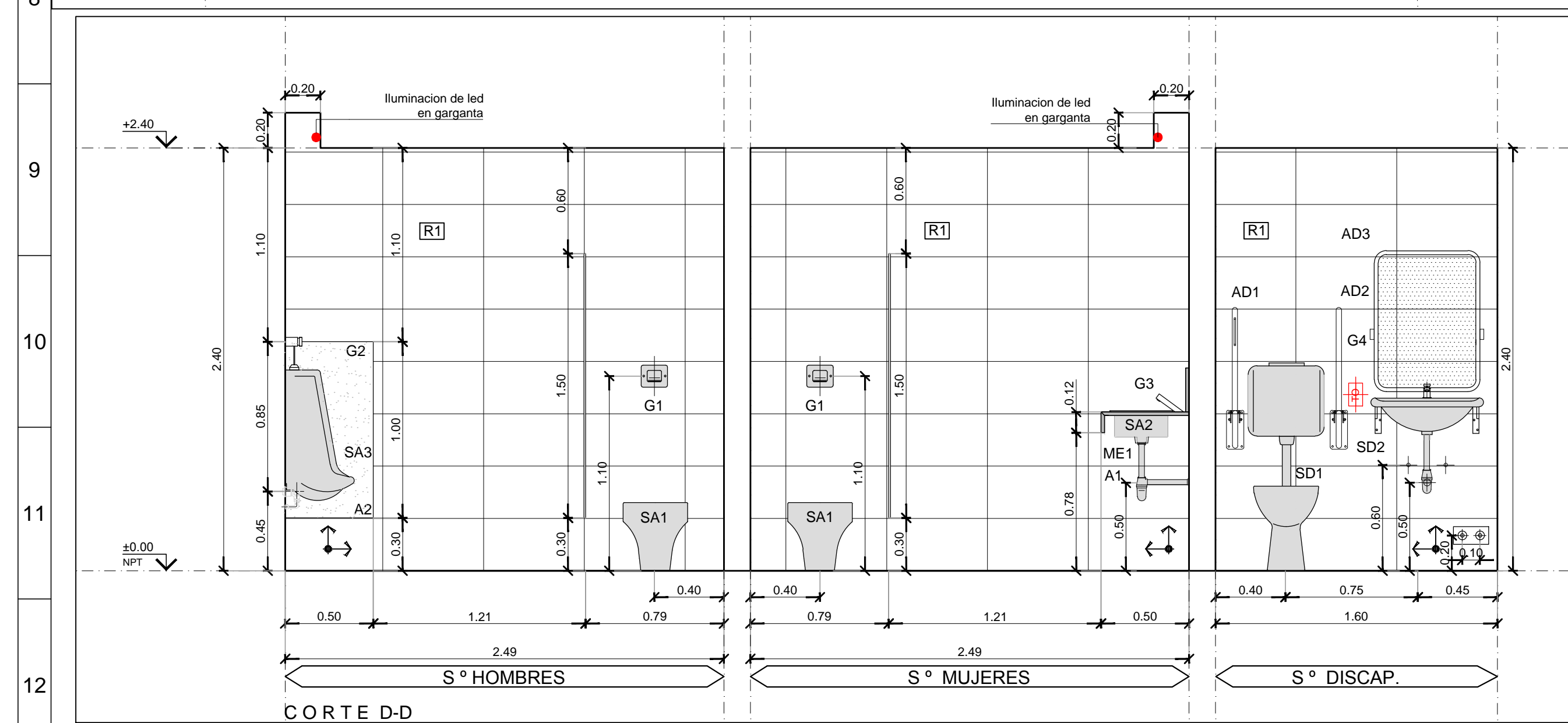
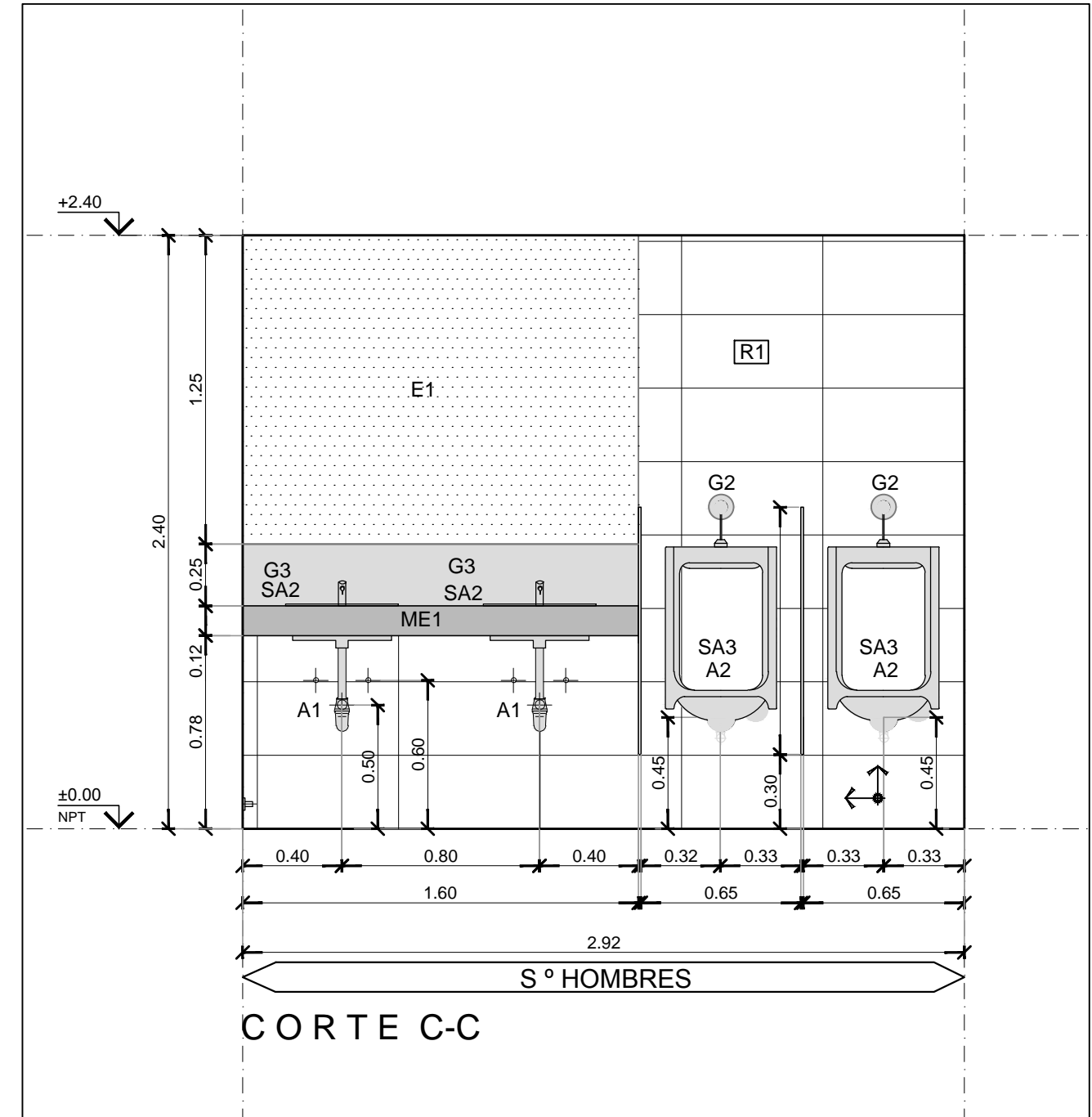
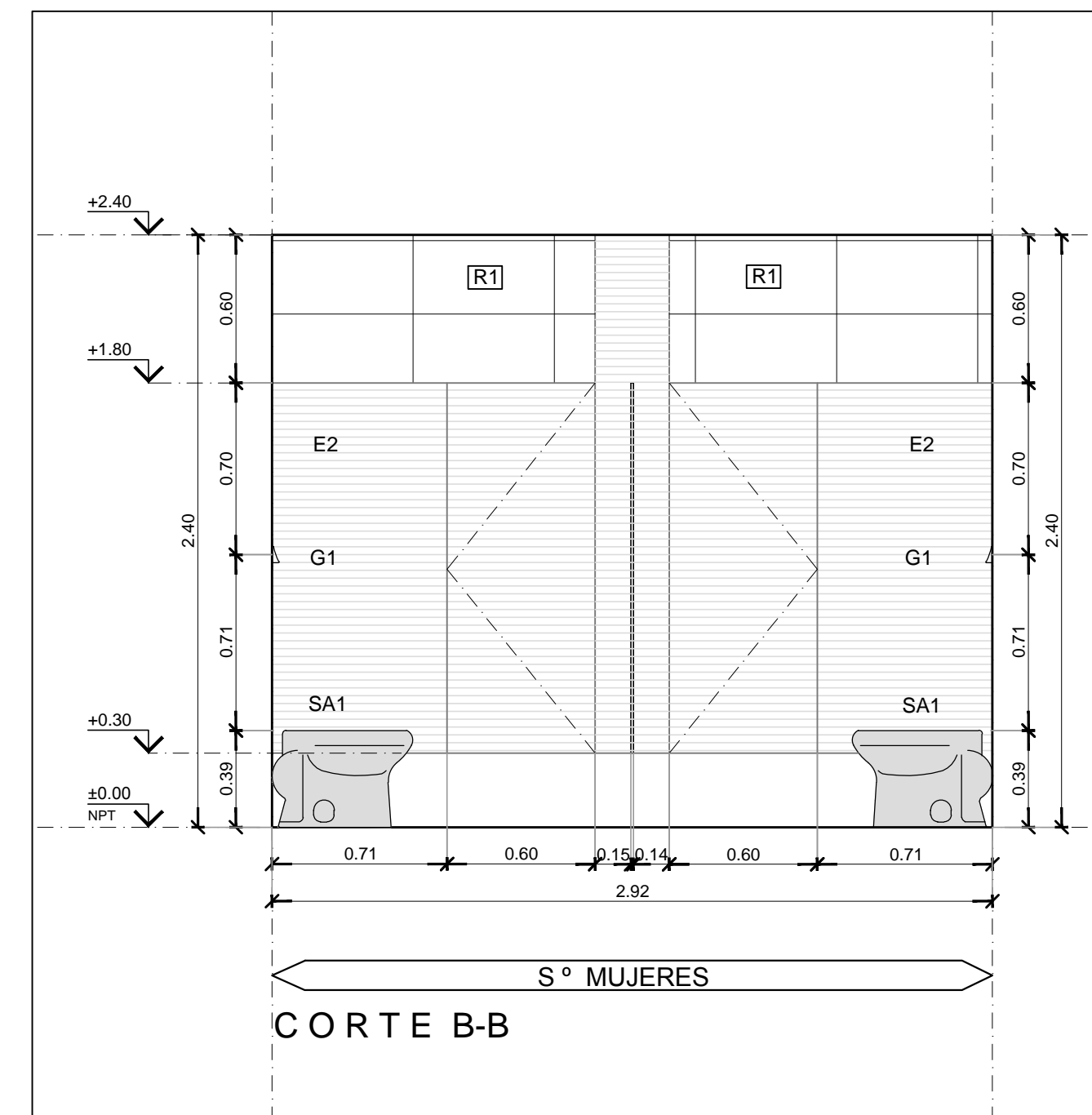
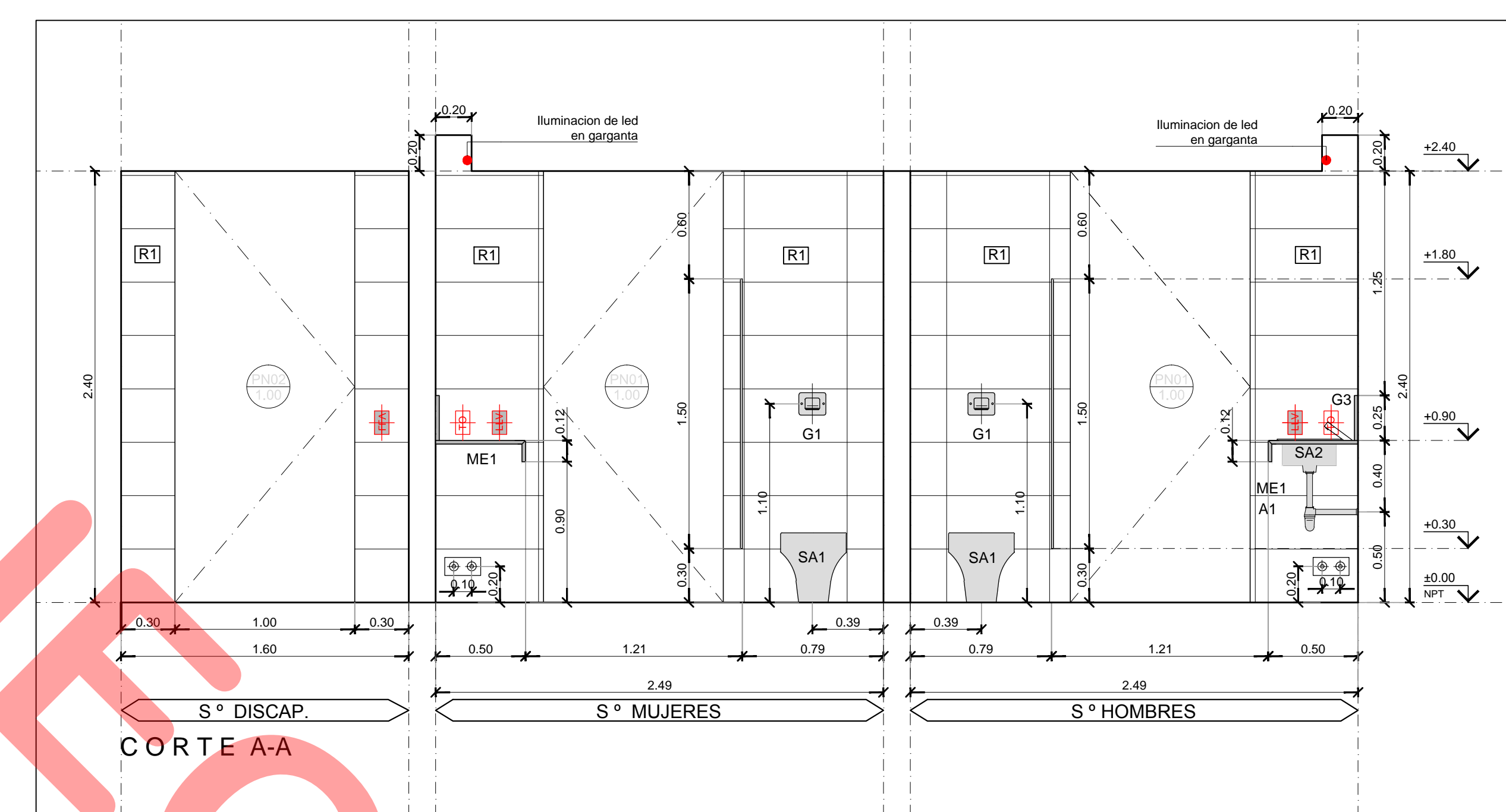
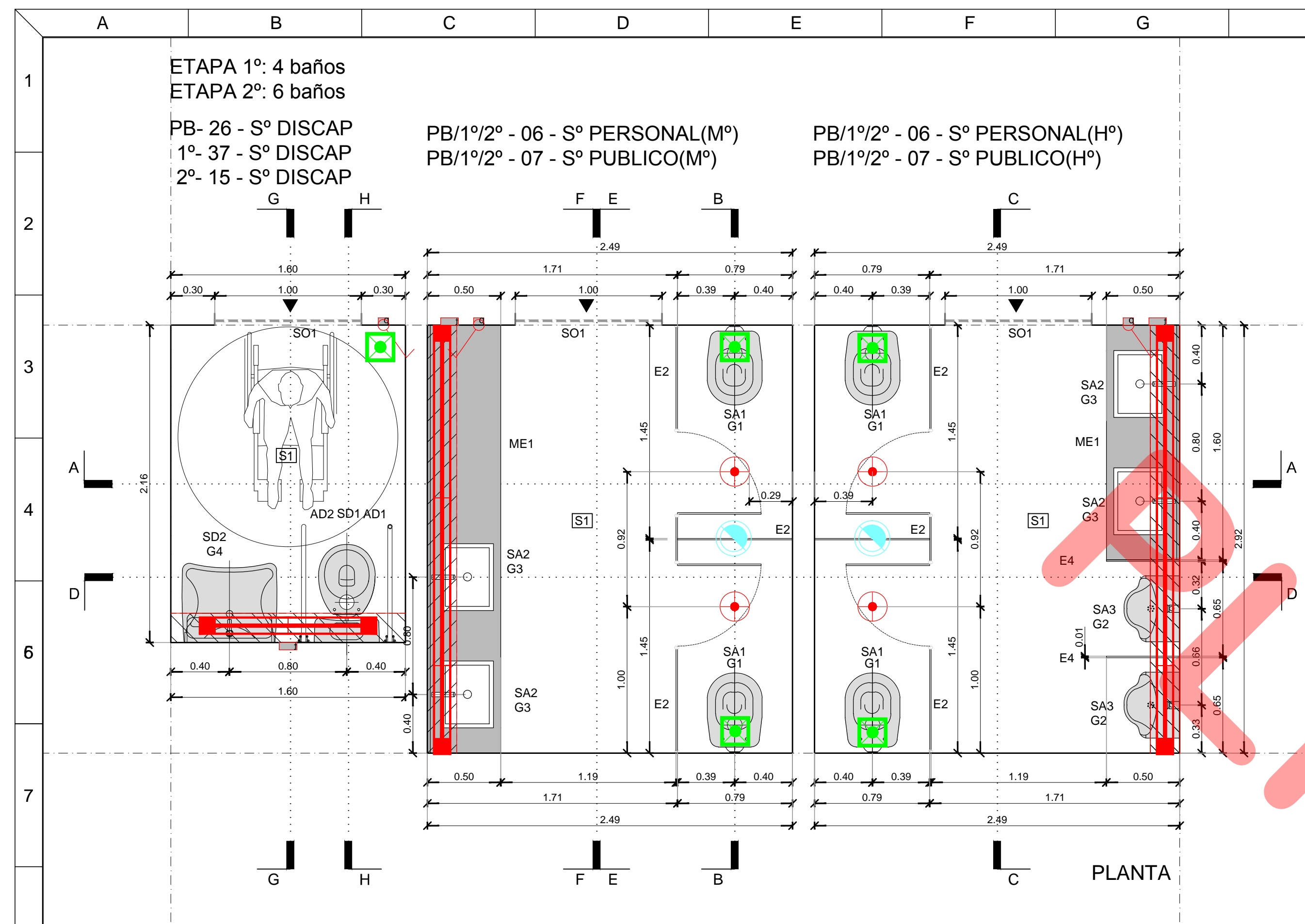

REFERENCIAS			
<b>SANITARIOS</b>			
SA1	Inodoro con línea Adriática de Ferum		
SA2	Batija Cuadra de Ferum		
SA3	Miradora Mural corto de Ferum		
SA4	Batija giratoria acero E 54		
SA5	Inodoro arriete IPN2-APM Cagaazu Maratunga		
SA6	Lavatorio arriete L.PN2-APM Cagaazu Maratunga		
SD1	Inodoro línea Espacio de Ferum		
SD2	Batija línea Espacio de Ferum		
<b>CRIFERIA</b>			
G1	Valvula FV para inodoros FV PRESSMATIC 0346		
G2	Valvula FV para mingitorios FV ECOMATIC 0362.01		
G3	Canta automática FV TRONC 0363.02T		
G4	Canta automática FV PRESSMATIC 0361.03A		
G5	Ducha FV ARZONA 0168B1		
G6	FV unim 0411.01		
G7			
<b>ACCESORIOS</b>			
A1	Desague rigido a la vista comado		
A2	Desague mingitorio		
AD1	Barra rebatible Ferum con portatelo y accionador		
AD2	Barra rebatible Ferum 60 cm. VIE88		
AD3	Especo rebatible Ferum Espacio		
<b>MESADAS</b>			
ME1	Mesada granito gris mara con frestn ingletado y zocabo superior		
<b>MUEBLES</b>			
MU1	Lockers 3 puertas		
MU2	Lockers 4 puertas		
<b>CIELORRASOS</b>			
<b>SOLIDOS</b>			
S1	Piso granito segun planta		
<b>REVESTIMIENTOS</b>			
R1	San keraco 28.7 x 57.20 rectificado blanco		
R1			
<b>EQUIPAMIENTO</b>			
E1	Especo final com		
E2	Tafeleros distribuidos tipo top box		
E3	Anafe electrico vibroceramico DOMEC 2 hornallas		
<b>ZOCALOS</b>			
<b>SOLIAS</b>			
SO1	Perfil T de acero inoxidable 3mm		
<b>LISTELES</b>			
<b>MAMPARAS</b>			
PROPIETARIO			
PODER JUDICIAL DE RIO NEGRO			
CJCC CIPOLLETTI			
MODIFICACIONES			
REV.	FECHA	DESCRIPCION	
D	A	A	
A	A	A	
A	A	A	
A	A	A	
A	A	A	
A	A	A	
A	A	A	
A	A	A	
A	A	A	
A	A	A	
PROYECTO			
CHERRENCO-COHAL-TYSBER-WICOWICZ-VIGHONI arquitectos			
11 de septiembre 2004 de C14384UF - Ciudad de Buenos Aires, Argentina TEL: 011 4790 2668			
DIBUJO	CONTRUO:	JU	
FECHA:	24.09.15	ESCALA:	1:25
DESCRIPCION			
DETALLES DE LOCAL			
ESTE DOCUMENTO CONTIENE INFORMACION DE PROPIEDAD DE CJCC. SU REPRODUCCION TOTAL O PARCIAL, SIN NUESTRA APROBACION ESCRITA ESTA PROHIBIDA.			
00	A	PARA LICITACION	
CJCC	DL	BA	04